

FILING SOLUTIONS THAT SAVE SPACE



- **INNOVATIVE**
- **INSPIRING**
- **RELIABLE**
- **SERVICE-ORIENTED**
- **EFFICIENT**
- **FLEXIBLE**

THE JALEMA CONCEPT OF SPACE

Vast amounts of information in every conceivable shape and form flow through modern organizations. Storing all the hard copies of documents, digital files, microfilms and other data carriers requires well-thought out filing solutions. Jalema has the expertise and the solution.

Jalema has specialized in contemporary filing systems with which the most widely varying flows of information can be effectively channeled. Jalema makes real solutions that will save time, space and money as well as creating order and providing insight. Jalema's products and services help companies and organizations maximize their performance each and every day.

With more than 60 of years experience in archiving solutions, Jalema guarantees reliability. Jalema is a family-run business that has 150 dedicated employees delivering its products and services worldwide. We are constantly adapting to market developments to ensure that our solutions fully meet our customers' needs and requirements.



E-mail: info@jalema.com
Internet: www.jalema.com

Jalema B.V.
Dr. Pottersstraat 11
P.O. Box 4802
5953 ZL, Pevenier
The Netherlands
Tel. +31 (0) 77 476 76 76
Fax +31 (0) 77 476 76 90

Jalema Inc.
7397 Washington Blvd.
Elkridge, MD 21075
USA
Tel. 800 - 362 - 5362
Tel. 410 - 796 - 5411
Fax 410 - 796 - 3090

Belgium
Jalema N.V.

France
Jalema France

THINK FILING IS OUT OF DATE? WHAT ABOUT:

Innovative

Information is available in more and more ways and through a growing number of sources. But more information does not necessarily mean more knowledge. It is only with clear-cut structuring and targeted management of information within your organisation that you can effectively manage operational processes based on facts. Jalema Information Management offers you competent advice, time and space-saving systems, and the essential resources to manage and control information, thereby enabling you to maintain a decisive, alert organisation, now and in the future.

Efficient and flexible

Jalema Information Management offers an integrated filing system for managing and controlling information in every conceivable form. A perfectly tailored package of efficient tools are specially designed for today's filing needs at both small and large institutions and companies, and can be implemented as a partial solution or complete concept.

Jalema develops and produces space and time-space filing systems that are based on a unique one-point suspension principle, meaning that the document folders are hung laterally – i.e. diagonally – on a profile. This translates into a 45% savings of space compared to traditional systems like filing cabinets. Moreover, the creative use of colour-coding techniques and sophisticated accessories – like the unique JalemaClip fastening mechanism and lab sheets (standard and customised) – lets you create an overview, resulting in significantly less time spent searching when filing and retrieving files.

Inspiring

A Solution for Every Need

• **Physical Archives**

Time and space-saving lateral filing systems with folders, CD/DVD files, cabinets (upright, mobile and revolving), racks, colour coding, handy accessories, and software for managing it all. Whether you are interested in suspension or upright filing, Jalema has the ideal solution for your situation.

• **Custom solutions**

In addition to our range of standard solutions, we manufacture just as many files, folders and systems to order, perfectly tailored to the customer's needs and requirements.



Did you know?

- 80 to 90% of the order flow in companies involves documents
- Paper usage is increasing
- More than 75% of company information is recorded on paper
- A single document is copied in an average of 5 times
- Employees spend a large percentage of their working hours searching for information
- Because they are so disorderly, archives are often a "low interest product"
- Digitizing a disorderly physical archive (files, binders, documents, etc.) is not an effective solution because the result is digital chaos.



JALEMA FILING SYSTEMS

Space-Saving Lateral Filing

Jalema develops and produces space and time-space filing systems that are based on a unique one-point suspension principle, meaning that the document folders are hung laterally – i.e. diagonally – on a profile. This translates into a 45% savings of space compared to traditional systems like filing cabinets. Moreover, the creative use of colour-coding techniques and sophisticated accessories – like the unique JalemaClip fastening mechanism and tab sheets (standard and customised) – lets you create an overview, resulting in significantly less time spent searching when filing and retrieving files.

The Advantages of Lateral Filing:

- Space-saving because the file is only as thick as its contents thanks to the use of the JalemaClip).
- Space-saving compared to four-drawer filing cabinets (45%).
- Several rows of files can be suspended on top of one another (up to 6 rows).
- Files can be easily removed and inserted with a simple movement of the hand (one-point suspension).
- Colour and coding options provide a better overview and save time.
- Options for attached and loose-leaf storage, or a combination of both.
- A single methodology for both static and dynamic working archives.

Which method do you choose?

You can choose from attached or loose-leaf filing and single or collective filing!!

- **Attached filing:** documents are perforated and bound together.
- **Loose-leaf filing:** documents are not perforated or attached using any kind of device.
- **Single storage:** documents are stored (loose-leaf or attached) in a file or folder that can be retrieved in its entirety from the system.
- **Collective storage:** documents are stored in a work file or inner file (loose-leaf or attached).

Once you've made your choice, please go to the section on Files and Folders. There you will be able to choose between the various product ranges. Each programme contains a file or folder and a clear description of suitability.

If you are uncertain as to which method suits your needs best, please contact one of our advisors for no-obligation advice.



JALEMA IN PRACTICE

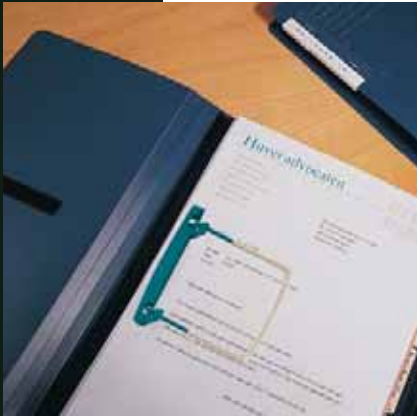

Lawyers • Huver Lawyers

Otanra work files and document-handling folders: presentable and durable

“You won’t believe you ever let your clients see you with any other kind of file.”

Files are the memory and backbone of a law firm. Although their contents may differ per case, their outer appearance is almost universally the same, i.e. a cardboard file with a few or many worn patches, depending on how intensively they’ve been used and for how long. But not the files at the Huver law firm in Venlo. That’s because this law firm works with Otanra files from Jalema, files that are made of heavy polypropylene and virtually indestructible. The files remain presentable and organized for years and years. Lawyer P.M.W. Huver explains their decision. “Until recently, there was pretty much only one system used in the legal profession – cardboard files fitted with elastic bands to hold them together when their contents became too thick. Because these files are often used for years on end and are frequently consulted and supplemented, they look less and less presentable as time goes by. Since we switched over to the new Otanra files last year, we no longer have this problem. Files up to 5 cm thick do not require an elastic band because they have a Velcro closure. Even files that are used intensively for long periods of time do not become unsightly. Once you’ve used an Otanra file, you won’t believe you ever let your clients see you with any other kind of file.” For more information go to www.jalema.com, see section Cases.



Banking • Rabobank Heel en Thorn

Arnato suspension files with Code in One labels

It is impossible to overestimate the value of a good and easy to use filing system for an organization which considers a reliable filing system to be of vital importance, even though it is not part of its core business activities. A good system is well-organized, accessible, flexible and user-friendly and makes efficient use of available space. In short, a good filing system is indispensable to the smooth execution of an organization’s business processes. It was therefore logical for the Rabobank Heel and Thorn to carry out a thorough review of its existing filing system when a natural opportunity presented itself: a move to a soon to be constructed accommodation. Raymond van der Borgh, a Facilities Management officer, served as the central coordinator during the new system selection process. “Because each division had its own issues, needs and requirements, each division appointed its own filing coordinator,” he says. “These coordinators identified the requirements to be met by the system, as well as any specific issues that had to be taken into consideration. Once you know exactly what you need, it becomes possible to start looking for the system that meets these needs. Based on the information we collected, we carried out a market analysis and held exploratory meetings with different suppliers. We also visited other banks which had recently completed similar initiatives. The results of our findings were fed back to the divisions, until we were all in agreement.” And that is how Jalema ended up being the final choice. Jalema delivered a lateral system with racks, outer files with colour coding and different types of inner files, with and without attachment mechanisms. For more information go to www.jalema.com, see section Cases.



Notary • Novitas Group

Racks, blue Arnato files with Codetabs

Annemarie Beijers is one of the Netherlands’ female notaries. Her office is located in Horst, where she looks after her clients’ interests with the aid of around 15 employees. Her ambition? Growth. Her filing system? Jalema. Exactly how is the archive structured? Annemarie explains: “In our firm we use several thousands of files. We have a separate file for each client, with its own code number, for which we use the Jalema code tabs. By using numbers combined with specific colours the archive space is extremely easy to use. You can quickly see which file you need, and even if a file has been archived incorrectly you are soon able to see that this is the case. The decision to use numbers instead of names is a result of the high need for privacy in our sector. Incidentally, if a client has a number of companies we will create separate files for these with serial numbers. We also use Jalema racks with Jalema profiles and blue Arnato files, the collective files and fastener files. The racks allow us to save considerable space in the archive. For more information go to www.jalema.com, see section Cases.

TABLE OF CONTENTS

FILES 7

Arnato
Otanra
Jaleco
Medi-System
Suspension file for shelves
Upright filing
Special files

CD STORAGE 29

MediaFiles
Desk Rack
CD/DVD (Wall) Rack

(COLOUR)CODING 33

Codetabs
Code in One
Code in One on Demand
Jockey Label Holder
Windows

ACCESSORIES 39

Tab Sheets
Attachment Mechanisms
Self-Adhesive Label Holder
Separation cards
File Box

RACKS/ CONVERSION KITS 47

Conversion kits
Racks

TRANSPORT TROLLEYS 53

Transport Trolleys

VARIOUS PRODUCTS 57

JIM Lite
Grafi-System

INDEX

A			
A4 inner files	13 – 17		
A4 pocket, self-adhesive	45		
A4 suspension files			
(label holders)	10, 11, 14, 17		
A4 suspension files			
(+ tab edge)	12		
Absence card	45		
Accessories	39 – 46		
Arnato	10 – 13		
Arnato inner files	13		
Arnato suspension files	10 – 12		
Attachment mechanism	42– 44		
B			
Business file	16		
C			
Cassettes	18		
CD/DVD (wall) rack	32		
CD desk rack	31		
CD pocket, self-adhesive	45		
CD storage	29 – 32		
CD-4 holder	31		
Code in One	36, 37		
Code in One labels	36, 37		
Code in One on Demand	37		
Codetabs	35		
Coding	33 – 38		
Collective file, inner file	13, 21		
Collective file, suspension file	11, 12, 14, 20		
Color Sign	34		
Colour coding	33 – 38		
Connecting pieces (File Box)	46		
Continuous filing rack	51		
Conversion kits	49		
Customised files	28		
Customised tab sheets	41		
D			
Desk rack	31		
Document folder, inner file	13, 15, 21		
Duo profile	49		
F			
Fastener file, inner file	13 – 17, 21		
Fastener file, suspension file	10 – 12, 19, 22, 23		
File Box	46		
File lifter	42		
Files	7 – 28		
Filing rack	51		
Folding file, suspension file	20		
Folio inner files	20, 21		
Folio suspension files	19, 20, 22, 23		
G			
Grafi-System	58		
I			
Indicator strips	38		
Info shelf	51		
Inner files, A4	13 – 17		
Inner files, folio	20, 21		
Insertion file	12, 23		
J			
Jaleco	20, 21		
Jaleco inner files	20, 21		
Jaleco suspension files	19, 20		
Jalema filing rack	51		
Jalema profile	49		
JalemaClip	42		
JalemaClip plus	44		
JalemaClip stickup	44		
JalemaClipex	43		
JIM lite	58		
Jockey	38		
Jockey labels	38		
L			
Label holder	38		
Label positioner	36		
Labels (File box)	46		
M			
Media wall-mounted rack	32		
MediaFiles	30, 31		
Medi-System	22 – 24		
Multi-file	11		
O			
Otanra	14 – 17		
Otanra cassettes	16, 18		
Otanra document-handling folders	14 – 16		
Otanra laminated	17		
Otanra suspension files	14, 17		
P			
PP files	14 – 16		
Profile supports	49		
Profiles	49		
R			
Racks	50, 51		
S			
Self-adhesive label holder	38		
Self-adhesive pockets	45		
Separation cards	45		
Special files	28		
Stripper-stickup	44		
Suspension file for shelves	25		
T			
Tab sheets	40, 41		
Tab sheets, blank	41		
Tab sheets, coloured	41		
Tab sheets, white	40		
Table arm	52		
Transport trolleys	53 – 56		
U			
Uni rack	50		
Upright filing	26, 27		
W			
Wall-mounted filing rack	52		
Wall rack CD's	32		
Wall unit	52		
X			
X-ray files	24		

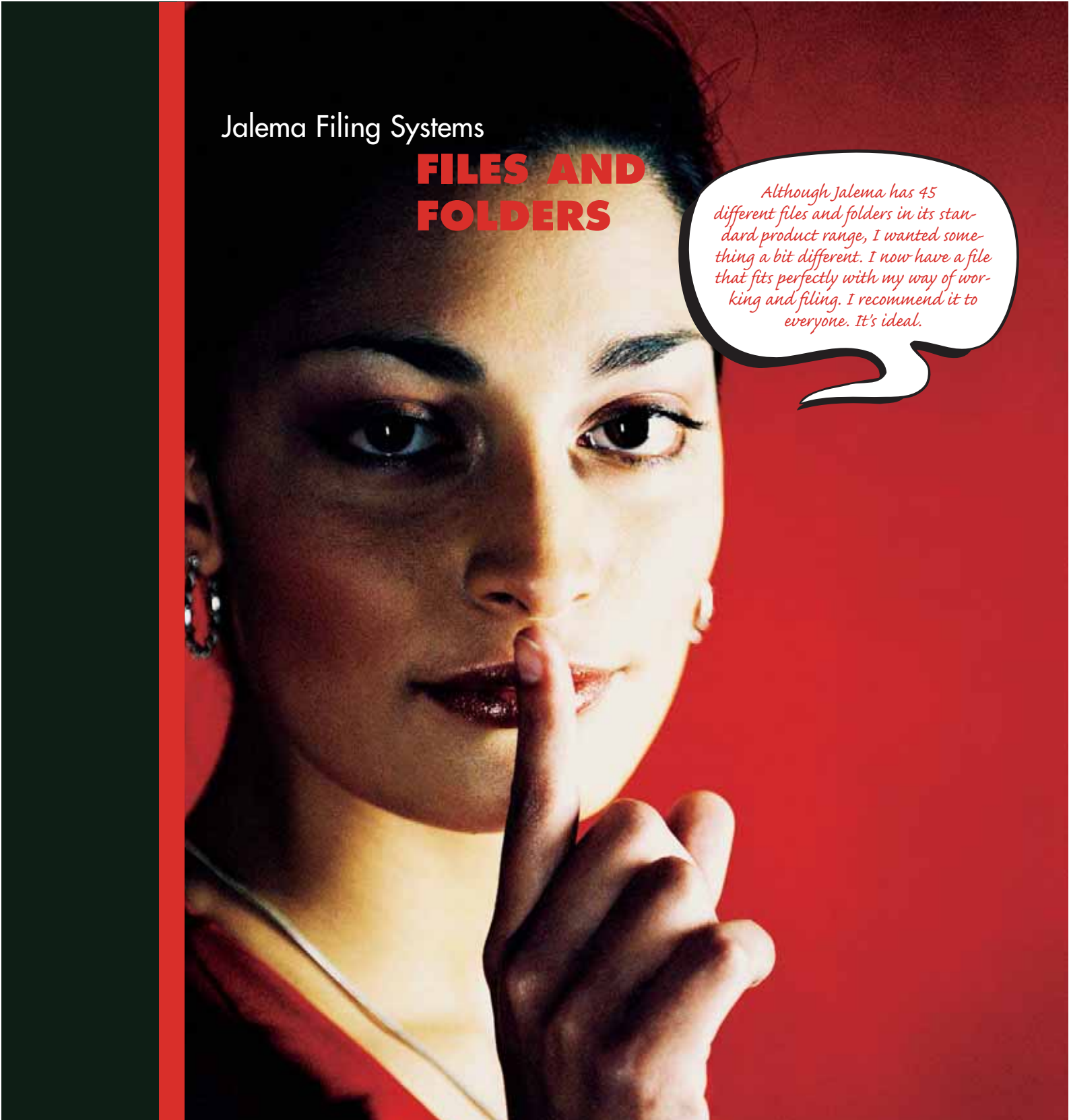

Jalema Filing Systems

FILES AND FOLDERS

Although Jalema has 45 different files and folders in its standard product range, I wanted something a bit different. I now have a file that fits perfectly with my way of working and filing. I recommend it to everyone. It's ideal.

There is no such thing as a paper-free office. Not now and not in the foreseeable future. Jalema files are therefore essential to maintain order and overview of the abundance of paper data carriers in today's companies, organisations and institutions. Jalema work files and document-handling folders save time and space when it comes to storing and retrieving letters, printed documents – with or without handwritten notes – folders, brochures, catalogues, newspaper cuttings, memos and other office documents. Jalema offers the following Product lines:

- Arnato
- Otanra
- Jaleco
- Medi-system
- Suspension file for shelves
- Upright filing
- Special files



FILES

S F I L E

A TOTAL SOLUTION IN ONE EFF



The unique Jalema single-point suspension system

Even the most far-reaching possibilities of the Internet have not resulted in what digital optimists once predicted, namely, the dwindling away of the administrative paper mountain. Indeed, the blessings of computerisation have only resulted in an even greater use of paper. There is even more correspondence and data processing taking place these days, resulting in large quantities of paper (on which all this information is printed) that subsequently require selective and proper filing. The only way to do so in a well-organised and efficient fashion is with a well thought out filing system. Jalema's speciality.

There is even more

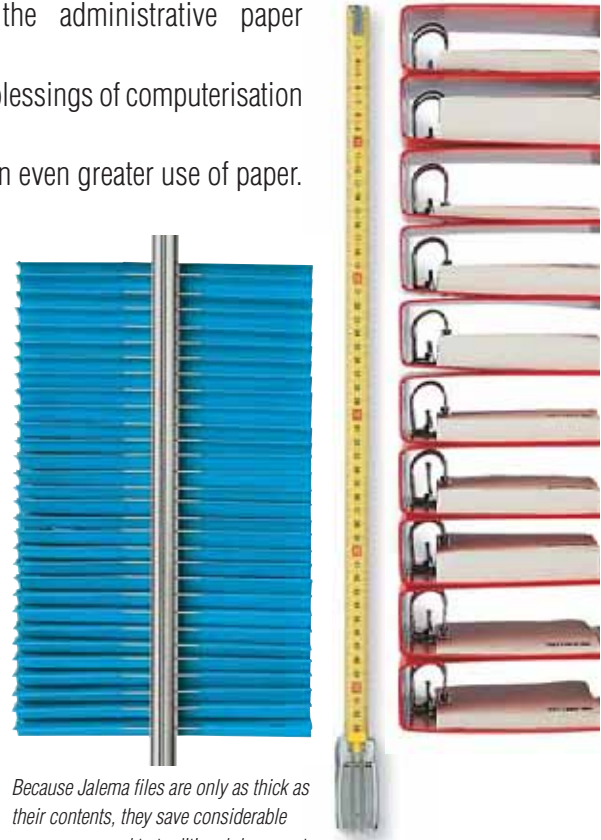

Because Jalema files are only as thick as their contents, they save considerable space compared to traditional document files.



The conversion kits for Jalema suspension files let you easily build the Jalema system into any existing cabinet.

REMOVE:

1. Push the file against the profile
2. Move the file upwards
3. Remove the file from the profile

INSERT:

1. Bring the file towards the profile
2. Insert file on the profile
3. Release the file



EFFICIENT FILING SYSTEM

The total solution for filing problems that literally continue to grow and grow can be found in a suspended file system. This system contains a unique profile on which files can be suspended alongside one another by means of a clever hook-on point. The profiles can also be placed on top of each other, making it possible to create multiple layers of files in a single cabinet or rack. The system fits inside virtually any existing cabinet, including yours!

The advantages are substantial:

- Efficient use of space.
- Because the files are only as thick as their contents, they clearly have an edge on traditional document files.
- Multiple rows of files can be suspended above each other, thus saving even more space.
- The files are easy to take along, even in a briefcase.
- The one-point suspension system reduces filing to a simple movement of the hand when hanging and removing files.
- Because the files are not standing but suspended, it is possible to colour code them efficiently and clearly.
- One methodology for both dormant and working archives.
- Possibilities for loose-leaf and attached filing, or a combination of both.
- The possibility to use inner files.
- The various coding possibilities contribute to a systematic and well-organised archive.
- Total solution includes cabinets, racks, mobile racks and accessories.
- Highly space-saving compared to four-drawer filing cabinets.
- Can be used with existing furniture.

Jalema files are available in various colours (red, grey and blue), making them ideal for organising different series of documents or departments. Alternative colours are also available. To systematically differentiate between individual files, Jalema also offers an extremely efficient coding method that reduces searching time to only a few seconds, and which makes it virtually impossible to insert files in the wrong place. Jalema also offers a wide selection of

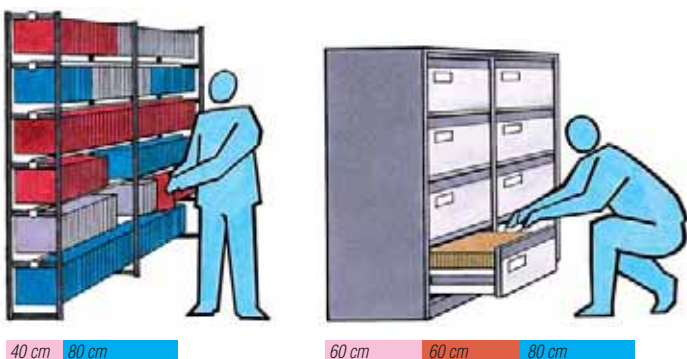

Lateral suspension file system saves several meters of office space and provides better organisation.



Three distinctive colours ensure optimal organisation and overview.



Colour coding the files reduces searching to a matter of seconds.

label holders, coloured and self-adhesive number sequences, and tailor-made self-adhesive coding stripes (Code in One) with numbers, letters, logos, dates, texts, barcodes, and so on, that can be fit to the file. We even offer the possibility to design your own labels using our Code in One on Demand software programme (see page 37).

Jalema's file programme contains not only solutions for everyday filing needs, but also for long-term storage, including closed collective files, document-handling folders with a variety of attachment mechanisms, loose-leaf folders, insertion files, inner files with JalemaClipex, pocket or flap. Letters, offers, invoices, pictures, CVs, orders, licences, and so forth are now easy within reach of hands. In short, there is only one efficient solution for all your storage needs:

Jalema.

A4 FILES

Arnato files meet all your filing needs: thin or thick, attached or loose-leaf, dynamic or static archive, the option to include inner files and suitability for holding any kind of document (up to size A4). The edge where users grab hold of the file is double folded and therefore twice as strong. Arnato files are available in A4 size and in the colours grey-07, blue-02 and red-15.

ISO-9706

Arnato files are made of colourfast 270-gram acid-free Colorkraft cardboard.

All ColorKraft files are produced in compliance with ISO standard 9706, an international standard that is often requested for files that are to be used in museums and public record offices.



There are 2 types of coding systems for the files: label holders that can be filled by the user (see page 38) and colour coding (see page 34).

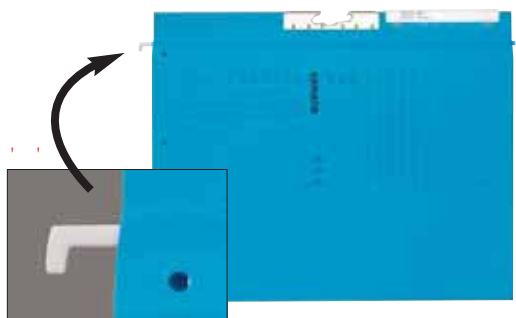

SUSPENSION FILES WITH JALEMA LABEL HOLDERS

Arnato Fastener Files with JalemaClip

This file is equipped with the characteristic yellow JalemaClip attachment mechanism, which allows you to easily thumb through documents like a book. The perforation holes won't tear and documents can be easily and quickly inserted and removed. What's more, you can make copies of the documents without having to remove them from the file. The JalemaClip won't make the file bulky, and the special clamping device prevents the contents from sagging. The files also come with an insert compartment for holding loose documents. The Arnato Fastener File with JalemaClip is ideal for files that require frequent insertion and removal of documents, such as when filing alphabetically or by document type.

Prod. no.	Description	Size/mm.	Stand. pack.	Capacity
55555**	Fastener File with JalemaClip (Suspension File)	320 x 260/250	100	20 mm

Colour code: ** = 02 blue, 07 grey, 15 red

Additional advantage, lateral and vertical suspension file in one

The folder above is also easily stored as a vertical suspension file in a desk drawer, which is very useful if you like to keep temporary projects to hand. This is made possible by equipping the file with a metal hanger. You can even attach the Jalema Jockey label holder to the top so you can see what the file holds. Afterwards, you remove the metal hanger from the file and re-use the file as a lateral suspension file in your filing cabinet.

Prod. no.	Description	Stand. pack.
6104000	Metal Hangers	100



Arnato Fastener File with Strip and Cover

The plastic-coated white strip and cover are handy for all chronologically and numerically arranged files. This file is also equipped with an insert compartment for loose documents.

Prod. no.	Description	Size/mm.	Stand. pack.	Capacity
5555002	Fastener File with Strip and Cover (Suspension File)	320 x 260/250	100	20 mm



Arnato Collective File with 1 Gusset

A file with two Jalema suspension points and closed at the back by a linen gusset so that papers and files won't fall out the other side. Can also be used in combination with one or more inner files of any kind. The inner files can be easily inserted and removed while the collective file remains suspended on the profile.

Prod. no.	Description	Size/mm.	Stand. pack.	Capacity
55581**	Collective File with 1 Gusset (Suspension File)	320 x 265	100	30 mm

Colour code: ** = 02 blue, 07 grey, 15 red



Arnato Collective File with 2 Gussets

Arnato also has the ideal solution for loose-leaf filing: the Arnato file with two Jalema suspension points and closed at the front and back by two cardboard gussets. Magazines, price lists, photographs, catalogues, and loose documents can be neatly contained in this file. If you open the file halfway, you can easily access the contents without having to remove them.

Prod. no.	Description	Size/mm.	Stand. pack.	Capacity
55582**	Collective File with 2 Gussets (Suspension File)	320 x 265	100	30 mm

Colour code: ** = 02 blue, 07 grey, 15 red



Multi-file

The Multi-File is a universal A4 file that keeps desks well organised and brings order to chaotic workplaces. It is the ideal order or project file, and has a convenient storage pocket for loose documents and materials. It also comes with the handy JalemaClip attachment mechanism. Files equipped with the JalemaClip are never thicker than their contents – as opposed to other standard document files – yet it is possible to easily insert and remove documents. The Multi-File comes in blue.

Prod. no.	Description	Size/mm.	Stand. pack.	Capacity
5201002	A4 Multi-File (Suspension File)	320 x 215 mm	50	40 mm



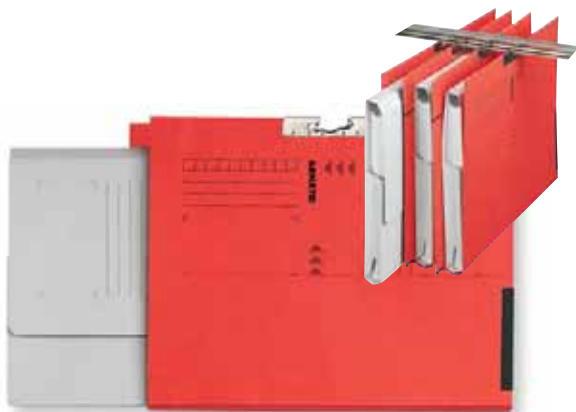
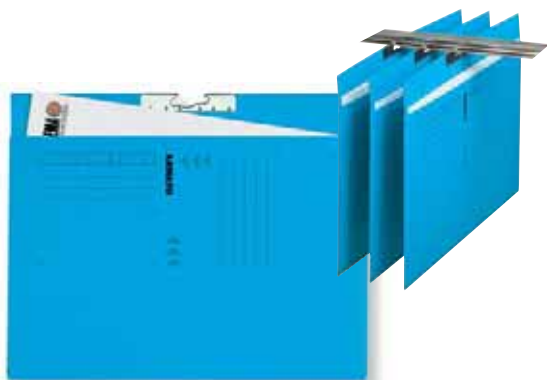
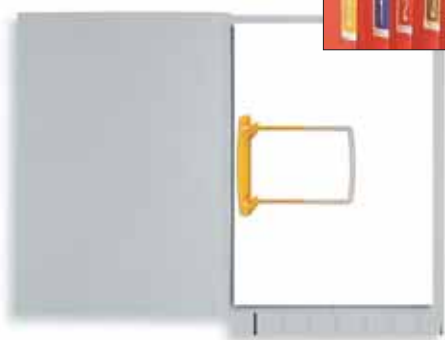

SUSPENSION FILES WITH TAB EDGE FOR COLOUR CODING

Arnato Fastener File with Tab and JalemaClip

This file has the added feature of a tab edge that protrudes on the front. The tab edge is designed for Codetabs or Code in One number sequences and/or labels. The fastening mechanism is the characteristic yellow JalemaClip. This flexible device lets you thumb through documents like a book, makes sure the perforation holes do not tear and that documents can be easily and quickly inserted and removed, and that you can make copies of the documents without having to remove them from the file. The Arnato Tab File with JalemaClip is ideal for files requiring frequent insertions and removals.

Prod. no.	Description	Size/mm.	Stand. pack.	Capacity
55655**	Fastener File with Tab and JalemaClip (+20 mm tab) (Suspension File)	320 x 260/250	100	20 mm

Arnato Insertion File

The Arnato insertion file is the perfect solution for very thin documents, such as a single form, order note or policy. These files are ideal space-savers.

Prod. no.	Description	Size/mm.	Stand. pack.	Capacity
55570**	Insertion File (Suspension File)	320 x 255	200	5 mm

Arnato Collective File with Tab and 1 Gusset

A file with two Jalema suspension points and closed at the back by a linen gusset, so that papers and files won't fall out the other side. Information compiled in an inner file is always within easy reach with a single movement of the hand. The collective file also offers space for one or more inner files, which can be easily inserted and removed while the collective file remains suspended in the rack or cabinet. This file is also equipped with a protruding tab edge on the front for colour coding.

Prod. no.	Description	Size/mm.	Stand. pack.	Capacity
55681**	Collective File with Tab and 1 Gusset (+20 mm tab) (Suspension File)	320 x 265	100	30 mm

Colour code: ** = 02 blue, 07 grey, 15 red

Customised Files

We can put together a customised file tailor-made to your requirements and wishes, as far as size, colour, attachment mechanism, colour coding and printing. For more information on the available options, see page 28, send an e-mail to info@jalema.com or contact us by phone.



A4 INNER FILES

The Arnato inner files are ideal for use with collective files and Otarra cassettes, though they can also be used as loose document-handling folders. Arnato inner files are made of Colorkraft cardboard and can be colour coded with Codetabs or self-adhesive Code in One labels.



The cardboard in chamois and grey comply fully with the strict ICN quality requirements 2, as laid down by the Dutch Public Records Act, which all government bodies must adhere to. This means that these files guarantee long-term storage and do not affect the documents being stored. This is more than just an acid-free file!

Arnato Fastener File with JalemaClipex

The handy JalemaClipex works in virtually the same way as the JalemaClip. The petrol-coloured JalemaClipex is PVC and acid free and therefore document-friendly. For all the advantages of this attachment mechanism, see the description under Accessories on page 43. This file comes in the colours blue-02, chamois-04, grey-07 and red-15, and can be used with the fastener on either the left or right side.

Prod. no.	Description	Size/mm.	Stand. pack.	Capacity
60558**	Fastener File with JalemaClipex (Inner File)	315 x 240/222	100	20 mm

Arnato Collective File with 2 Gussets

Wallet model for loose-leaf filing. The contents are enclosed by gusset closures on the sides and a dust flap, making it possible to access the contents without having to remove them from the file. Comes in the colour grey.

Prod. no.	Description	Size/mm.	Stand. pack.	Capacity
6055907	Collective File with 2 Gussets (Inner File)	315 x 230	100	30 mm

Arnato Document Folder with Flap

A flap on the front side keeps documents from falling out of the file and, when filed laterally, the contents are not visible from the outside. The flap also has space for indicating contents. The protruding tab edge on the file is suitable for colour coding. Comes in the colour grey.

Prod. no.	Description	Size/mm.	Stand. pack.	Capacity
6055207	Document Folder with Flap (Inner File)	325 x 240	200	20 mm

Arnato Document Folder

The Arnato Document Folder is designed for loose-leaf compiling, holding and storing of A4 documents. Oversized flaps on 3 sides keep documents secure and ensure they do not fall out of the file.

Prod. no.	Description	Size/mm.	Stand. pack.	Capacity
6055407	Document Folder (Inner File)	315 x 230	100	25 mm



POLYPROPYLENE FILES FOR BU

The Otanra range of files consists of an outer file (collective type suspension file) and 6 document-handling folders made of 0.5 mm blue polypropylene, and a business file made of blue cardboard. These durable files are suitable for bulky contents. The outer file and most of the inner files can hold up to 5 centimetres of materials, therefore ideal for use in law and administrative offices. They are sturdy and attractive, suitable for filing large quantities of papers.

Special files

If you are looking for an unusual design and/or imprint, contact Jalema.

SUSPENSION FILES



Otanra Collective Files (A4 and folio)

For filing thick inner folders. Made of 0.5 mm blue plastic (polypropylene), this file is equipped with a gusset on the front, also made of 0.5 mm polypropylene. The file also has label holder perforation holes for Jockeys. Printed with boxes and lines for jotting down information.

Prod. no.	Description	Size/mm.	Stand. pack.	Capacity
5680002	Collective File with 1 Gusset in blue PP A4	320 x 250/275	25	50 mm
5682002	Collective File with 1 Gusset in blue PP folio	350 x 250/275	25	50 mm

DOCUMENT-HANDLING FOLDERS



Otanra Fastener File with JalemaClipex (A4 and folio)

For storing large quantities of documents with a fastener. Made of 0.5 mm plastic (polypropylene). Equipped with the document-friendly JalemaClipex attachment mechanism and a flap on the right side. There is also a text window on the front (90 x 55 mm). The file has a Velcro closure and is unprinted.

Prod. no.	Description	Size/mm.	Stand. pack.	Capacity
6080002	Fastener File with JalemaClipex in blue PP A4	318 x 230	25	50 mm



LKY CONTENTS

Otanra Document Folder with Flaps (A4 and folio)

For storing large quantities of loose-leaf documents. Folding file style with 3 large flaps. There is a text window on the front (90 x 55 mm). The folder has a Velcro closure and is unprinted.

Prod. no.	Description	Size/mm.	Stand. pack.	Capacity
6080502	Document Folder with 3 Flaps in blue PP A4	318 x 230	25	50 mm



Otanra Clip File (A4)

The Clip File perfectly combines attached and loose-leaf filing. There is a pocket on the left on the inside that holds 5 to 10 mm of materials. The pocket closure can be easily adjusted from 5 to 10 mm to accommodate the thickness of the contents. The inner right side is equipped with a JalemaClipex and holds 15 to 20 mm.

The contents are protected by an additional cover flap on the right side. The elastic band covers both corners, keeping the contents neatly in place. There is a transparent pocket on the front (inside dimension: 61 x 92 mm) with a thumb index and indicator strip.

Prod. no.	Description	Size/mm.	Stand. pack.	Capacity
6075002	Clip File in blue PP A4	318 x 235	25	25 mm



Otanra Clip File Duo (A4)

The Clip File Duo is equipped with 2 JalemaClipex attachment mechanisms on tab sheets, making it possible to easily categorise the contents without having to add separate dividers. Each fastener holds up to around 20 mm of materials. There is an adjustable insert compartment at the back of the folder that holds 5 to 10 mm of materials.

An elastic band helps keep the contents neatly in place inside the folder. There is also a transparent window on the front (inside dimension: 301 x 55 mm) with a thumb index and indicator strip on each tab sheet for indicating the contents of each section.

Prod. no.	Description	Size/mm.	Stand. pack.	Capacity
6075502	Clip File Duo in blue PP A4	318 x 245	25	50 mm

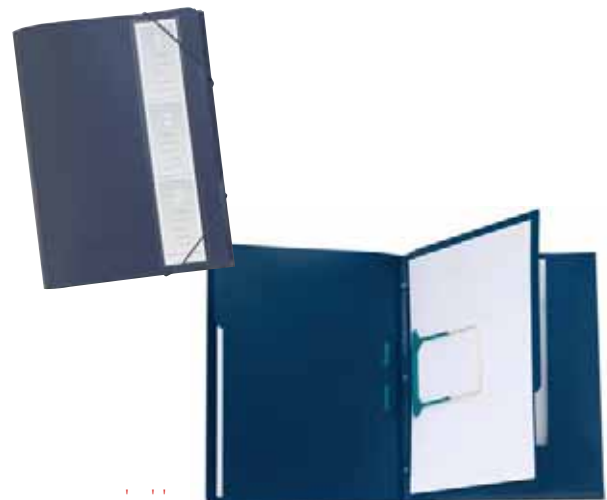

FILES



Otanra Project Fastener File (A4)

To file a large quantity of documents in a well-organised fashion, the Otanra Project Fastener File has a total of 4 attachment mechanisms on tab sheets. The first and third tab sheet are equipped with the JalemaClipex and hold around 15 mm. The second and fourth tab sheet are equipped with a strip and plastic cover and hold up to 10 mm. There is also a pocket on the rear flap that holds 5 to 10 mm. There are elastic bands around the corners for closing the file. There is a transparent pocket on the front (inside dimension: 301 x 55 mm) with a thumb index and indicator strip with 5 numbers for indicating the contents per tab sheet.

Prod. no.	Description	Size/mm.	Stand. pack.	Capacity
6076002	Project Fastener File in blue PP A4	318 x 245	25	60 mm



Business File

A attractive file with five attachment mechanisms and gussets for loose-leaf as well as attached filing of documents by subject. The file is comprised of the following: first a self-adhesive stripper, then three strips and covers, next a gusset with a capacity of 3 cm, and, finally, another JalemaClip.

The Business File is made of 270 gram (free of acid and chlorine) blue Colorkraft cardboard and is printed with lines for indicating contents and a coding strip.

Prod. no.	Description	Size/mm.	Stand. pack.	Capacity
6060002	Business File	315 x 250	50	20 mm

OTANRA LAMINATED

Do you have a large amount of information to store and would prefer to

keep it in a single, presentable file? The new Otanra files are the ideal solution. Otanra laminated files can store up to 5 cm of documents. Made of sturdy 300 gram cardboard with a laminated layer, these files are durable and wear-resistant. The 3 work files are designed for daily use and can be stored laterally in the suspension file with suspension point.

Special files

If you are looking for an unusual design and/ or imprint, contact Jalema.



Otanra Folding File

An A4 file with two Jalema suspension points and an open front and back. This folding file remains suspended in the archive and is used in combination with inner files that are slid in and out of the file. It has perforation holes on both sides for coding with the universal Jockey label holder. It is also possible to use Code Tabs with this file by adhering them onto the printed lines.

Prod. no.	Description	Size/mm.	Stand. pack.	Capacity
5685000	Otanra A4 laminated Folding File	320 x 275	50	50 mm

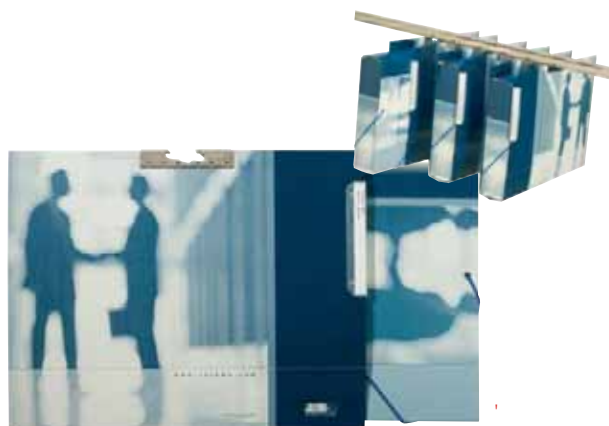

Otanra Inner File with JalemaClip

This A4 file is ideal for the attached filing of documents. The unique JalemaClip attachment mechanism makes it possible to easily remove and insert documents and leaf through them like a book. The file has two elastic bands for keeping contents firmly in place.

Prod. no.	Description	Size/mm.	Stand. pack.	Capacity
6085000	Otanra A4 Inner File with JalemaClip	318 x 250/ 230	50	50 mm



Otanra Inner File with 3 Flaps

This A4 inner file is ideal for storing loose documents. It has 3 large flaps for protecting contents and keeping them from shifting. The two elastic bands also help keep contents firmly in place and prevent the front of the file from slipping away.

Prod. no.	Description	Size/mm.	Stand. pack.	Capacity
6085200	Otanra Inner File with 3 Flaps	318 x 230/ 225	50	50 mm



Otanra Combi Inner File

This A4 file combines attached and loose-leaf document storage. The first section has the unique JalemaClip and the second has 3 dust flaps. Storage capacity is 2.5 and 3 cm. Elastic bands keep contents firmly in place.

Prod. no.	Description	Size/mm.	Stand. pack.	Capacity
6085500	Otanra Combi Inner File	318 x 250/ 230	50	50 mm



OTANRA CASSETTES

The most durable solution for filing bulky documents is the Otanra cassette. Made of 1.2 mm thick transparent anthracite polypropylene, the cassettes are ideal for loose-leaf filing, for all types of inner files, catalogues, phonebooks, and other bulky contents. In addition to the usual A4 and folio models, this durable, long-lasting filing sensation also comes in size 350 x 290 mm. All cassettes are provided with punched holes for Jockeys and are available with open or closed fronts, 60 or 80 mm wide.



Otanra Open A4/Folio Cassette

The open cassettes are ideal for use with inner files, as they can be easily inserted and removed from the front without having to remove the cassette from the profile. These cassettes are equipped with a reinforced bottom at the front, enabling them to hold up to 2.5 kg.

Prod. no.	Description	Size/mm.	Stand. pack.	Capacity
5671832	Cassette; Open A4	320 x 260	25	80 mm
5673632	Cassette; Open Folio	350 x 260	25	60 mm
5673832	Cassette; Open Folio	350 x 260	25	80 mm



Otanra Closed A4/Folio Cassette

The closed cassettes are suitable for storing inner files and are particularly ideal for loose-leaf documents, like reports, catalogues, annual reports and accounts. All cassettes come with a black plastic ring. Score marks on the sides make it possible to easily bend the cassette halfway for better visibility of contents.

Prod. no.	Description	Size/mm.	Stand. pack.	Capacity
5672832	Cassette; Closed A4	320 x 260	25	80 mm
5674632	Cassette; Closed Folio	350 x 260	25	60 mm
5674832	Cassette; Closed Folio	350 x 260	25	80 mm



Otanra 350x290 mm Open Cassette

This cassette differs from the open folio cassette in that it is extra high, making it more suitable for larger inner files.

Prod. no.	Description	Size/mm.	Stand. pack.	Capacity
5675632	Cassette; Open	350 x 290	25	60 mm



JALECO FOLIO FILES

Jalema produces a line of folio files under the name Jaleco, comprising 6 outer files and 5 inner files.

The wide selection of different versions makes it possible to meet all possible requirements and desires, whether you are filing loose-leaf or attached, individually or collectively (i.e. with one or more inner files), only a few contents or a large quantity of bulky contents. The outer files are made of 225 gram unbleached brown Kraft cardboard and come with label holder perforation holes.

For more information on label holders, see page 38.

Special files

If you are looking for an unusual design and/ or imprint, contact Jalema.

OUTER FOLIO FILES

Jaleco Fastener File with JalemaClip

This file is fitted with the JalemaClip attachment mechanism. This flexible device lets you thumb through documents in the file like a book, makes sure the perforation holes do not tear, that documents can be easily and quickly inserted and removed, and that you can make copies of the documents without having to remove them from the file. The JalemaClip won't make the file bulky (as opposed to other document filing mechanisms). This file also comes with an insert compartment for holding loose documents. The Jaleco Fastener File with JalemaClip is ideal for files that require frequent insertion and removal of documents, such as when filing alphabetically or by document type.



Prod. no.	Description	Size/mm.	Stand. pack.	Capacity
5025500	Fastener File with JalemaClip (Outer File)	350 x 260/250	100	20 mm

Jaleco Fastener File with Strip and Cover

Naturally the well-known and extremely popular attachment mechanism of strip with cover has been included in the Jaleco line. The plastic-coated white strip and cover are handy for all chronologically and numerically arranged files. This file is also equipped with an insert compartment.



Prod. no.	Description	Size/mm.	Stand. pack.	Capacity
5025000	Fastener File with Strip and Cover (Outer File)	350 x 260/250	150	20 mm



Jaleco Collective File with 1 Gusset

A file with two Jalema suspension points and closed at the back by a black linen gusset so that documents won't fall out the other side. Can also be used in combination with inner files, which can be easily inserted and removed while the collective file remains suspended on the profile.

Prod. no.	Description	Size/mm.	Stand. pack.	Capacity
5028100	Collective File with 1 Gusset	350 x 265	150	30 mm

Jaleco Collective File with 2 Gussets

Jalema also has an effective solution for loose-leaf filing. The Jaleco Collective File is equipped with two Jalema suspension points and is closed at the front and back by two cardboard gussets. Perfect for storing magazines, photographs, and loose documents.

Prod. no.	Description	Size/mm.	Stand. pack.	Capacity
5028200	Collective File with 2 Gussets (Outer File)	350 x 265	100	30 mm

Jaleco Folding File

The Jaleco Folding File has two Jalema suspension points and is open at the front and back. The file remains suspended in the archive and is used in combination with inner files, which can be easily inserted and removed from the file. There are two versions available: 265 and 290 mm high.

Prod. no.	Description	Size/mm.	Stand. pack.	Capacity
5027000	Folding File (Outer File)	350 x 265	150	30 mm
5027900	Folding File (Outer File)	350 x 290	100	30 mm

INNER FOLIO FILES



The cardboard in chamois and grey comply fully with the strict ICN quality requirements 2, as laid down by the Dutch Public Records Act, which all government bodies must adhere to. This means that these files guarantee long-term storage and do not affect the documents being stored. This is more than just an acid-free file!

Jalema produces four different types of inner files for use with the folding file and collective file with 1 gusset as part of the Jaleco line. Jaleco inner files can also be used separately as loose document-handling folders. The inner files are made of colourfast 270 gram Colorkraft (free of acid and chlorine) cardboard and come with an all-purpose imprint, making them suitable for a variety of coding options.



Jaleco Fastener File with JalemaClipex

This inner file is equipped with the document-friendly JalemaClipex attachment mechanism. The JalemaClipex offers the same advantages as the JalemaClip, but has the added advantage of being PVC and acid free. This means that, even after 100 years of storage, this clip will have no adverse effects whatsoever on the documents it holds. The JalemaClipex has proved its document-protecting values with routine use to many satisfied users. The Jaleco fastener file with JalemaClipex is available in chamois, blue, grey and red.

Prod. no.	Description	Size/mm.	Stand. pack.	Capacity
60028*0	Fastener File with JalemaClipex (Inner File)	348 x 240/222	100	20 mm

Colour code: * = 2 (blue), 4 (chamois), 7 (grey), 9 (red)



Jaleco Fastener File with Strip and Cover

The strip, cover plate and sliding protective cover are free of plasticizers and heavy metals that could damage documents. This file is available in the colour chamois and can be used with the fastener on either the left or right side.

Prod. no.	Description	Size/mm.	Stand. pack.	Capacity
6002740	Fastener File with Strip and Cover (Inner File)	348 x 240/220	100	20 mm



Jaleco Collective File with 2 Gussets

Inner file for storing loose-leaf documents. The contents are secured by expanding gussets on the sides and a dust flap. Colour: chamois. Capacity: 30 mm.

Prod. no.	Description	Size/mm.	Stand. pack.	Capacity
6002940	Collective File with 2 Gussets (Inner File)	348 x 230	100	30 mm



Jaleco Document Folder with Flap

If you need to file loose-leaf documents or take them with you, this folder is an excellent solution because it comes with a flap on the bottom right half on the inside that ensures that documents do not fall out of the folder. There is also a 20 mm protruding tab edge that is suitable for coding. Available in the colour chamois. Capacity: 10 mm.

Prod. no.	Description	Size/mm.	Stand. pack.	Capacity
6002240	Document Folder with Flap (Inner File)	355 x 240	200	20 mm



SOLUTIONS FOR HEALTHCARE



Jalema provides a wide range of standard medical files. The full range meets all possible requirements of the user, whether you want to file loose leaf or bound, as single or collective filing, whether you have thin or thick dossiers, ... The files are produced from special Rejekt cardboard - an easily

writable and crease-resistant type of cardboard - or of robust brown Kraft liner cardboard. The gripping edge of the files is glued double, so the file is less quickly damaged in those important places and there are no sharp corners. Filing on the basis of the date of birth, the most common method used in the health care sector, is obviously also possible. There is also plenty of space on the files for adding other relevant information or coding. There are also special windows for filling in the name, date of birth or other information on the patient. You can also stick a label on the file containing this information.

Colour Coding

A good coding method is vital. It results in 40 % less time spent searching. Filing on the basis of the date of birth, is the most common method used in the health care sector. For various coding possibilities see page 34.



Medical file with JalemaClip

This medical file is equipped with the flexible JalemaClip attachment mechanism. This clip lets you leaf through your file as you would a book and helps prevent the perforated holes from getting torn. The JalemaClip also makes it possible to copy each of the documents without having to remove them from the file. The complete sheet remains legible. Inserting and removing documents is also a cinch with the JalemaClip. Another major advantage is that the file is only as thick as the number of documents in it. In other words, the JalemaClip won't make the file bulky! This medical file also comes with an extra pocket for storing loose sheets. The medical files with JalemaClip are the perfect solution if you work with dividers or frequently insert documents in different places in the file. The file is made of reject cardboard. The maximum filing capacity is 20 mm.

Prod. no.	Description	Size/mm.	Stand. pack.	Capacity
5405200	Medical file with JalemaClip, A4	320x260	100	20 mm
5405500	Medical file with JalemaClip, folio	350x260	100	20 mm



Medical file with strip and cover

This file is the same as the one described above with the exception of the addition of a strip and cover as the attachment mechanism. The lacquered white metal strip and white plastic cover are convenient for filing medical documents numerically or chronologically, or if you only seldom insert additional documents. This file also comes with a convenient pocket. The medical file with strip and cover is made of reject cardboard. The maximum filing capacity is 20 mm.

Prod. no.	Description	Size/mm.	Stand. pack.	Capacity
5403200	Medical file with strip and cover, A4	320x260	200	20 mm
5403500	Medical file with strip and cover, folio	350x260	200	20 mm



Medical insert file

If you only require a thin file because you file only a few documents per patient, the medical insert file is the ideal solution, as it takes up very little space. It is made of reject cardboard and has a maximum filing capacity of 5 mm.

Prod. no.	Description	Size/mm.	Stand. pack.	Capacity
5409200	Medical insert file, A4	320x260	300	5 mm
5410200	Medical insert file, folio	350x260	300	5 mm

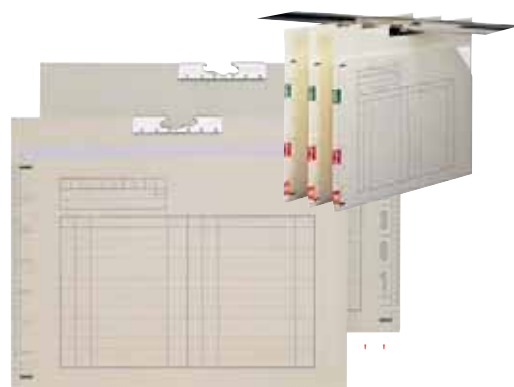

Medical collective file

The collective file has 2 suspension points and a black linen gusset closure on the front. The file is highly convenient because it lets you file a large number of documents separately or in one or more inner folders. Medical documents or inner folders can be inserted or removed easily on the front without having to remove the folder from the profile. The collective file is made of Kraftliner cardboard and has perforation holes for the Jalema Jockey (label holder). The maximum filing capacity is 30 mm.

Prod. no.	Description	Size/mm.	Stand. pack.	Capacity
5408100	Medical collective file	350x265	150	30 mm



X-RAY FILES

These files are specially made for putting together a well-organised, easily accessible and space-saving x-ray archive.

Because the files hang from a profile, the x-rays do not become damaged. The files may also be coded, by date of birth for example, for which an easy-to-read imprint has been printed on the folder. Jalema x-ray files are made of sturdy brown 230 gram Whitekraft. The folders have a white liner on the inside, making it easy to slide x-rays and inner folders in and out.



X-ray insert file with flap

This file has a special reinforced flap above the compartment to keep the x-rays dust-free. The cardboard is folded double around a reinforcement strip on the bottom of the flap, as a result of which the edge of the cardboard does not feel sharp when opening the file. The file has 1 suspension point and a maximum filing capacity of 5 mm. When hanging (laterally) on the profile, the compartment is on the left side.

Prod. no.	Description	Size/mm.	Stand. pack.	Capacity
5350075	X-ray insert file with flap	460x395	100	10 mm



X-ray file with 2 compartments

This x-ray file is the same as the one described above, except that it comes with a second compartment (310 mm high) in which you can store notes, file recent x-rays or separate recent x-rays from older ones. The flap measures 120 mm and provides dust-free closure for both compartments.

Prod. no.	Description	Size/mm.	Stand. pack.	Capacity
5350675	X-ray file with 2 compartments	460x395	80	2 x 5 mm



X-ray collective file

This file has two suspension points and a black linen gusset closure on the rear side halfway between the bottom and top. This prevents any inner folders, x-ray envelopes or x-rays from falling out the back. This collective file can be used with or without inner folders. There is a crease halfway across the file which can be folded outwards, making it even easier to access the contents. The collective file has a maximum filing capacity of 30 mm. Both files have perforation holes for the Jalema Jockey (label holder).

Prod. no.	Description	Size/mm.	Stand. pack.	Capacity
5350500	X-ray collective file	460x400	70	30 mm

If you are looking for an unusual design and/or imprint, contact Jalema. Our filing consultants can advise you on the most suitable x-ray file for your requirements.



SUSPENSION FILE FOR SHELVES



With the suspension file, Jalema is introducing a whole new way to work with files and shelves. In addition to the familiar lateral suspension file with the unique one-point suspension system, Jalema is now offering a suspension file with 2 suspension points that can be suspended under a shelf. Standard racks and shelved cabinets are commonly used for filing, so the suspension file for shelves is designed to optimally use cabinet shelving while at the same time you can enjoy the advantages of our lateral suspension file system, including the possibility to use colour coding, barcodes, etc.

This sturdy file is fully lined on the front, manufactured of 270 gram Colorkraft cardboard, and available in blue, grey and red. The back is closed halfway, keeping the inner file or loose-leaf documents neatly in place without shifting and easy to remove. The ends of the profiles are coated so that the files slide smoothly and noiselessly along the edge of the shelf. The files can be used as either V-bottom, 15 mm or 33 mm box-bottom files. Because it has a flexible base, the outer file is never thicker than its contents.

The advantages of Secolor suspension files for shelves:

The suspension file for shelves is an exceptional file made of high-quality materials with the following advantages:

- Available in 3 colours (blue, grey and red).
- Constructed of sturdy 270 gram Colorkraft cardboard.
- Highly durable because front and bottom are fully lined.
- Can be used as either a V-bottom, 15 mm or 33 mm box-bottom file.
- Outer file is never thicker than its contents.
- Closure on the back serves as a block for the inner file, making it easier to remove.
- Can be easily and quickly suspended under a shelf.
- Can also be used as a vertical file in pullout frames in racks.
- Easy to interconnect.
- Profiles have coated ends so that they slide smoothly along the edge of the shelf.
- Can also be used in pullout frames.

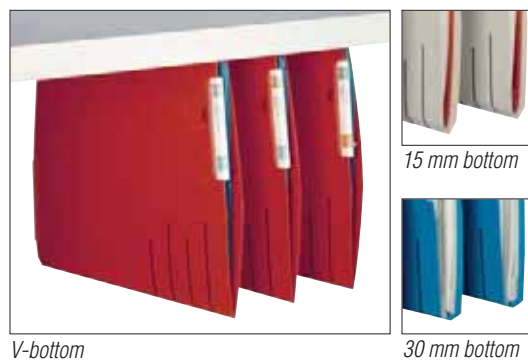

FILES



Suspension file for shelves with Jalema Jockey Label Holder



Pullout frame with Jalema Suspension file

Jalema Jockey Label Holder

Jalema files are equipped with perforation holes for the Jockey and are supplied with Jalema Jockey label holders. The files can be easily linked using the Jalema Jockey, which can be coded as desired (with colour coding or otherwise. See page 36 for more information). The Jalema Jockey can be attached in 3 different positions at the top of the file.

Advantages:

- The Jalema Jockey is unbreakable and the text is visible on both the front and side.
- The indication strips can be printed by the sheet or select portion of the sheet.
- It is possible to link databases to the print job, making the indication strips easy to create without time-consuming writing or typing.
- Various colour-coding options possible.
- The label holder has bevelled edges so that the inner files do not become stuck.

Description	Stand. pack.	Order no.
Secolor suspension file for shelves (280 x 320 mm)	50 (incl. 50 Jockeys)	33150**

** = Enter colour no.: blue (02), grey (07), red (15)

UPRIGHT FILING



JIM Lite

A software program that registers and manages your files and documents easily. You can download it for free on www.jalema.com.



Basic Rack

Two standard racks for upright filing are available in light grey. These filing racks comprise an extremely solid storage system. Both racks have 7 shelves, each of which has a turned-up edge that ensures that files do not fall off the shelf at the back. Since files will not remain upright if the shelf is only partly filled, clips can be used to hold the files in place. These clips can be attached anywhere under the shelf.

Prod. no.	Description	Size/mm.	Stand. pack.
6501100	Basic Rack; 7 shelves, upright	2274 x 1030 x 350	1
6501200	Basic Rack; 7 shelves, upright	2274 x 1230 x 350	1
6510000	Clips for 350 mm shelf		1



Jalema has two files in its range that are ideal for upright filing: the Document Folder with Flap and the Fastener File with JalemaClipex. Both files are available in A4 and folio sizes.

Colour Coding

Colour coding lets you save up to 40% of the time normally spent searching for that one file. For more detailed information on colour coding options, see the chapter on Colour Coding, starting on page 33.



A4 and Folio Document Folder with Flap

The Document Folder with Flap is the ideal solution for storing or taking along loose-leaf documents. This folder is fitted with a flap on the bottom right half of the inside so that documents do not fall out and has a 20 mm protruding tab edge that can be used for coding.

Prod. no.	Description	Size/mm.	Stand. pack.	Capacity
6055207	Annato Document Folder with Flap (Colour: grey)	325 x 235	200	10 mm
6002240	Jaleco Document Folder with Flap (Colour: chamois)	355 x 230	200	10 mm



You can also easily create a Fastener File by combining the Document Folder with the self-adhesive Stripper Stickup or JalemaClip Stickup.



A4 and Folio Fastener File

The Fastener File is equipped with the document-friendly JalemaClipex. For all the advantages of this attachment mechanism, see the description in the Accessories section on page 42. The Fastener File with JalemaClipex is ideal for files that require frequent insertion, such as when filing alphabetically or by document type. This file is available in blue, chamois, grey and red and can be used with the fastener on the left or right side. The short side of the file also has an imprint for colour coding.

Prod. no.	Description	Size/mm.	Stand. pack.	Capacity
60558**	Annato Fastener File with JalemaClipex	315 x 240	100	20 mm
Colour code: ** = 02 (blue), 04 (chamois), 07 (grey), 15 (red)				
60028*0	Jaleco Fastener File with JalemaClipex	350 x 240	100	20 mm
Colour code: * = 2 (blue), 4 (chamois), 7 (grey), 9 (red)				



SPECIAL FILES



A few of the available options:

- Unusual formats.
- Multiple or different attachment mechanisms in a single file (such as the Jalema-Clip and/or strip and plastic cover).
- Extra insert compartment or none at all.
- Different coloured file (full colour or colour of your company).
- Print (such as the company logo, building, name or text).
- Various printing techniques (such as varnished print).

SPECIAL FILES

Jalema has an extensive line of files in various styles and colours. What some people don't realise is that Jalema also offers the option to personalise a file. The possibilities are numerous.

We have years of experience in producing both standard and special files. We also have our own production facilities, which allow us to optimally serve our clients.

Perhaps you would like to order one of the standard files but would prefer a different size or design, or perhaps you wish to print your own logo on the file. At Jalema we have the expertise and capacity to offer these options and more.

On this page you see a full colour file with JalemaClip we produced for the Dutch chapter of Amnesty International.

Contact us to enquire about all the possibilities (without any obligation).





Jalema Filing Systems

CD STORAGE

I had loads of CDs and DVDs lying around, but couldn't find anything anymore. The Jalema CD wall-mounted filing rack has storage space for as many as 1000 CDs and only takes up 1 m².

Jalema also offers integrated storage solutions and a wide range of products for digital storage media, such as CDs and DVDs. The basis of this line of products is a variety of different storage files that can be used with universal label holders (Jalema Jockey) or well-marked colour coding labels. The files are stored in a well-organised and space-saving fashion in racks or stylish, stackable desk racks.



CD STORAGE SYSTEM

MEDIAFILES

EFFICIENT FILING AND OPTIMAL ACCESSIBILITY



MediaFiles save time and space when storing CDs, CD-ROMs, DVDs, diskettes, Jaz disks and Zip disks.

Data filing has literally been given new dimensions with the increasing availability of digital storage media (such as CD-ROMs, DVDs and Zip disks). All conceivable kinds of files of virtually unlimited size can be filed on compact disks and, in this way, be made accessible for reference or reuse – that is, if filed efficiently and in an orderly fashion. Jalema's MediaFiles enable you to do both.



You file something away with the intention of retrieving it quickly and easily again later. Laterally suspended MediaFiles from Jalema are designed for precisely that – efficient filing and optimum accessibility. Each MediaFile is equipped with a Jalema suspension point that enables you to hang the file laterally – i.e. diagonally – on a profile. The profile is mounted in convenient wall racks and desk racks, though it can also be built into any other kind of cabinet, rack, or safe. Lateral filing is particularly space-saving and makes it possible to quickly and easily insert and remove MediaFiles. MediaFiles are also extremely easy to locate, thanks to Jalema's unique colour-coding system. Colour coding enables you to find files 40% more quickly, time you would have otherwise spent searching for that one CD-ROM or disk. MediaFiles come with label holder perforation holes for the Jalema Jockey, making colour coding easy and effective, and resulting in a well-organised, orderly archive.

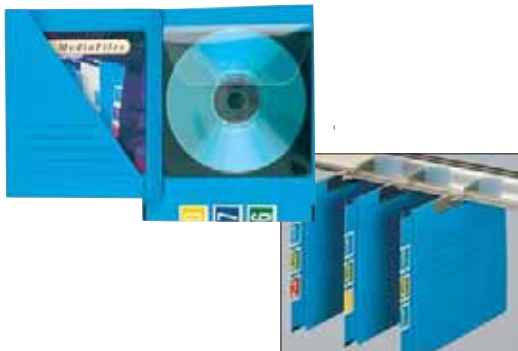

MediaFile Insert

MediaFile Insert is made of sturdy blue 270 gram Colorkraft cardboard and can be opened like a book. On the right side of the MediaFile is a plastic pocket with a soft lining, in which a total of 2 CDs can be inserted. On the left is an insert compartment for the accompanying booklet or other information. This unique space-saving version is ideal for users who do not wish to save the CD case.

Prod. no.	Description	Stand. pack.
5651502	MediaFile Insert	100



ACCESSIBILITY OF DIGITAL STORAGE MEDIA

MediaFile Collect

MediaFile Collect is also made of blue Colorkraft cardboard, but holds 2 or 3 CD-ROMs or Zip discs along with their cases. This MediaFile remains suspended on the profile, making it possible to easily insert and remove cases.

Prod. no.	Description	Stand. pack.
5653002	MediaFile Collect	100

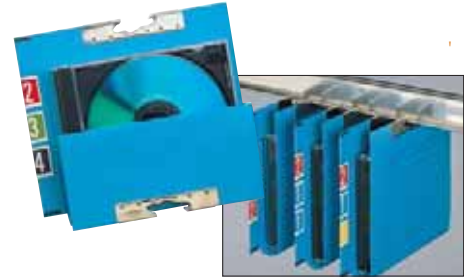

MediaFile Case

MediaFile Case is made of hard PVC and has a transparent pocket for holding a CD or Zip disk (including the case). It is also equipped with a thumb slide for easily removing the CD as well as lines on the back for jotting down information on the contents.

Prod. no.	Description	Stand. pack.
5650018	MediaFile Case	25



CD-4 Holder

If more than one CD is needed for a project, you can store the CDs together in the CD-4 holder that - like the name says - holds 4 CDs, even though the case is no thicker than a normal CD case. An ingenious mechanism makes it possible to store 4 CDs in the same amount of space that would normally be required for only one. Talk about an efficient storage solution!

Prod. no.	Description	Stand. pack.
6095000	CD-4 Holder	10



Desk Rack

A convenient and attractively designed desk rack is available that holds 25 PVC MediaFiles or 50 cardboard MediaFiles. The Desk Rack also offers the added advantage of being stackable.

Prod. no.	Description	Stand. pack.
6496600	Desk Rack	1



CD STORAGE SYSTEM



CD/DVD (Wall) Rack

Jalema designed 2 solid metallic racks for filing CD/DVD's and MediaFiles, one which can be mounted on the wall and the other one is a standing rack. With both racks you can file many cd's efficiently and you have an optimum accessibility of your digital storage media. The racks are available in the colour light grey. Both racks are 1000 mm width and 200 mm deep. One meter only can hold several hundred CD's. The wall rack has 5 profiles with a height of 1074 mm and the standing rack has 10 profiles with a height of 2114 mm. The length of each profiles is 955 mm.

Prod. no.	Description	Size/m.	Capacity
6496700	CD/DVD Wall Rack; 5 profiles	4,77 m	1
6496800	CD/DVD Rack; 10 profiles	9,55 m	1



Colour Coding

MediaFiles can be located easily and quickly thanks to Jalema's unique colour-coding system. With colour coding, you can find your storage media 40% more quickly, time that would otherwise be spent searching. For more details on Jalema's colour-coding system, see the Colour Coding section starting on page 33.



CD Transport

Jalema has developed a special transport trolley for moving large quantities of CDs from one department to the next. For more details, see the Transport Trolleys section starting on page 53.

Storing MediaFiles in your existing cabinet or rack

Jalema also offers the possibility to install the profiles on which the MediaFiles are suspended in your existing furniture. Jalema supplies conversion kits for all types of cabinets, racks, safes, and the like. For more details, see the section on Racks/Conversion Kits starting on page 47.



A man with grey hair, wearing a dark suit, white shirt, and striped tie, is shown from the chest up. He has a serious expression. A speech bubble is positioned to his right. The background is a dark, textured pattern. The text 'Jalema Filing Systems' is in the top left, and 'COLOUR CODING' is in large white letters across the top. The speech bubble contains a testimonial.

Jalema Filing Systems

COLOUR CODING

Clever colour coding frees up time so I can concentrate on my core activities.

With colour coding, files can be located in a matter of seconds, saving you up to 40% of the time normally spent searching. The result is a more orderly, timesaving filing system and, equally as important, no more lost files! With Jalema's coloured self-adhesive Codetabs on files and folders, it is virtually impossible to misfile. If a file is hung where it doesn't belong, it stands out immediately because the colour sequence is interrupted. Any combination of colours is possible. Jalema supplies individual labels (with numbers, letters and dates) and pre-labelled files that are tailor-made to fit in with your coding method. Another option offered by Jalema is Code in One on Demand, sophisticated and user-friendly software for printing your own personal labels.

SAVE TIME, SPACE AND ENERGY

Where can you still do the same amount of work in half the time? In your archive, that's where! Jalema's unique colour-coding system enables you to locate files 40% more quickly. What's more, you save a considerable amount



of time because your files are filed correctly almost every time. With such an efficient filing system, you can spend your time and energy focusing on your core business.

Well-Organised and Easy to Use

Jalema's colour coding method can be adapted to comply with your own coding system. You determine the meaning of each colour, designating different colours for the day, month, year, client number, postal code, accounts receivable number, job number or even a combination of all of these. Suppose you've organised your archive by four-digit order numbers. Every colour code label would then contain four cells, each with a different colour for the different digits, resulting in four levels of continuous colour bars.

The advantage of Jalema colour-coding systems:

- Colour coding results in 40% less searching time;
- You can use your own coding method;
- Files can be optionally delivered pre-labelled;
- Any combination of numbers, letters, logos, texts, barcodes and dates is possible.

COLOR SIGN

De Color Sign labels meten 24 x 8 mm en zijn leverbaar in 12 verschillende kleuren. Ze zitten verpakt per 100 vel à 60 stuks of 3.000 per rol. Van de vellen is er tevens een assortie verpakking. Met de labels kunt u verschillende coderingsmogelijkheden realiseren. Voor de veelgebruikte codering op geboortedatum worden meerdere methodes gehanteerd.

Op de puntjes achter het artikelnummer dient u de gewenste kleurnummers in te vullen:

02 = donkerblauw	08 = groen	15 = rood	25 = assortie
03 = bruin	09 = lichtblauw	18 = wit	
06 = geel	13 = oranje	19 = zwart	
07 = grijs	14 = paars	21 = rose	



Art.nr.	Omschrijving	Stand. verpakking
62600..	Color Sign labels, 100 vel à 60 stuks per kleur, per doosje	1
62700..	Color Sign labels, 3.000 stuks per kleur, per rol	1
6275002	Dispenser voor 3 rollen Color Sign labels	1



WITH COLOUR CODING



CODETABS

Codetabs are laminated self-adhesive coloured tabs that are available either blank or with numbers, letters, year date printed on them. Codetabs make it possible to develop your own personal coding system. Whether you file by order number, client name, postal code, date or client number, Codetabs are the answer. The use of Codetabs on files rules out the possibility of misfiling. If a file is hung incorrectly, it stands out immediately because the colour pattern is interrupted. The year date tabs are also convenient because they make it immediately apparent the year in which the file was created, thereby also making it obvious when the file is old enough to be removed from the archive. Virtually all Jalema files come with a coding strip consisting of six 26 mm sections and one 21 mm section. The Codetabs are adhered to these sections, thus creating an efficient coding system.

Codetabs are available in a variety of different packagings.

The **number tabs** come in handy rolls of 500 labels or in bags of 100. You can also order a complete kit that contains 10 rolls of 500 with all the numbers (0-9) in a handy display. Individual **letters** are available in bags of 100 or rolls of 500, as well as the option to order the entire alphabet in a box of 26 x 100 letters A-Z. Jalema also offers a complete kit that includes 4,000 **assorted Codetabs** (letters A-Z) and comes with a handy storage box. **Blank stickers** are available in rolls of 500 and **date stickers** in rolls of 1,000.

Codetabs, numbers

Prod. no.	Description	Stand. pack.
6280006	Codetab; roll of 500 x "0"; yellow	1
6280009	Codetab; roll of 500 x "1"; light blue	1
6280015	Codetab; roll of 500 x "2"; red	1
6280010	Codetab; roll of 500 x "3"; light green	1
6280007	Codetab; roll of 500 x "4"; grey	1
6280028	Codetab; roll of 500 x "5"; gold	1
6280008	Codetab; roll of 500 x "6"; dark green	1
6280002	Codetab; roll of 500 x "7"; dark blue	1
6280013	Codetab; roll of 500 x "8"; orange	1
6280019	Codetab; roll of 500 x "9"; black	1
6280525	Codetab; 10 rolls of 500 x "0-9"; display	1
6281006	Codetab; bag of 100 x "0"; yellow	1
6281009	Codetab; bag of 100 x "1"; light blue	1
6281015	Codetab; bag of 100 x "2"; red	1
6281010	Codetab; bag of 100 x "3"; light green	1
6281007	Codetab; bag of 100 x "4"; grey	1
6281028	Codetab; bag of 100 x "5"; gold	1
6281008	Codetab; bag of 100 x "6"; dark green	1
6281002	Codetab; bag of 100 x "7"; dark blue	1
6281013	Codetab; bag of 100 x "8"; orange	1
6281019	Codetab; bag of 100 x "9"; black	1
6282014	Codetab; bag of 100 x "L"; purple	1
6282006	Codetab; bag of 100 x "M"; yellow	1
6283009	Codetab; bag of 100 x "N"; light blue	1
6283015	Codetab; bag of 100 x "O"; red	1
6283010	Codetab; bag of 100 x "P"; light green	1
6283007	Codetab; bag of 100 x "Q"; grey	1
6283028	Codetab; bag of 100 x "R"; gold	1
6283008	Codetab; bag of 100 x "S"; dark green	1
6283002	Codetab; bag of 100 x "T"; dark blue	1
6283013	Codetab; bag of 100 x "U"; orange	1
6283019	Codetab; bag of 100 x "V"; black	1
6283003	Codetab; bag of 100 x "W"; brown	1
6283021	Codetab; bag of 100 x "X"; pink	1
6283014	Codetab; bag of 100 x "Y"; purple	1
6283006	Codetab; bag of 100 x "Z"; yellow	1
6283200	Codetab; 26 x 100 "A-Z"	1
6283525	Codetab; "A-Z"; 4000 assorted labels in storage box	1
6281507	Codetab; roll of 500 x "Q"; grey	1
6281508	Codetab; roll of 500 x "S"; dark green	1
6281509	Codetab; roll of 500 x "N"; light blue	1
6281510	Codetab; roll of 500 x "P"; light green	1
6281513	Codetab; roll of 500 x "U"; orange	1
6281514	Codetab; roll of 500 x "V"; purple	1
6281515	Codetab; roll of 500 x "O"; red	1
6281519	Codetab; roll of 500 x "V"; black	1
6281521	Codetab; roll of 500 x "X"; pink	1
6281528	Codetab; roll of 500 x "R"; gold	1

Codetabs, blank/date stickers

Prod. no.	Description	Stand. pack.
6285002	Codetab; roll of 500 blank; dark blue	1
6285003	Codetab; roll of 500 blank; brown	1
6285006	Codetab; roll of 500 blank; yellow	1
6285007	Codetab; roll of 500 blank; grey	1
6285008	Codetab; roll of 500 blank; dark green	1
6285009	Codetab; roll of 500 blank; light blue	1
6285010	Codetab; roll of 500 blank; light green	1
6285013	Codetab; roll of 500 blank; orange	1
6285014	Codetab; roll of 500 blank; purple	1
6285015	Codetab; roll of 500 blank; red	1
6285018	Codetab; roll of 500 blank; white	1
6285019	Codetab; roll of 500 blank; black	1
6285021	Codetab; roll of 500 blank; pink	1
6285028	Codetab; roll of 500 blank; gold	1
6286006	Codetab; roll of 1000 x "00"; yellow	1
6286109	Codetab; roll of 1000 x "01"; light blue	1
6286215	Codetab; roll of 1000 x "02"; red	1
6286310	Codetab; roll of 1000 x "03"; light green	1
6286407	Codetab; roll of 1000 x "04"; grey	1
6286528	Codetab; roll of 1000 x "05"; gold	1
6286608	Codetab; roll of 1000 x "06"; dark green	1
6286702	Codetab; roll of 1000 x "07"; dark blue	1
6286813	Codetab; roll of 1000 x "08"; orange	1
6286919	Codetab; roll of 1000 x "09"; black	1

Codetabs, letters - roll of 500

Codetabs, letters - bag of 100

Prod. no.	Description	Stand. pack.
6282009	Codetab; bag of 100 x "A"; light blue	1
6282015	Codetab; bag of 100 x "B"; red	1
6282010	Codetab; bag of 100 x "C"; light green	1
6282007	Codetab; bag of 100 x "D"; grey	1
6282028	Codetab; bag of 100 x "E"; gold	1
6282008	Codetab; bag of 100 x "F"; dark green	1
6282002	Codetab; bag of 100 x "G"; dark blue	1
6282013	Codetab; bag of 100 x "H"; orange	1
6282019	Codetab; bag of 100 x "I"; black	1
6282003	Codetab; bag of 100 x "J"; brown	1
6282021	Codetab; bag of 100 x "K"; pink	1
6281402	Codetab; roll of 500 x "G"; dark blue	1
6281403	Codetab; roll of 500 x "J"; brown	1
6281406	Codetab; roll of 500 x "M"; yellow	1
6281407	Codetab; roll of 500 x "D"; grey	1
6281408	Codetab; roll of 500 x "F"; dark green	1
6281409	Codetab; roll of 500 x "A"; light blue	1
6281410	Codetab; roll of 500 x "C"; light green	1
6281413	Codetab; roll of 500 x "H"; orange	1
6281414	Codetab; roll of 500 x "L"; purple	1
6281415	Codetab; roll of 500 x "B"; red	1
6281419	Codetab; roll of 500 x "I"; black	1
6281421	Codetab; roll of 500 x "K"; pink	1
6281428	Codetab; roll of 500 x "E"; gold	1
6281502	Codetab; roll of 500 x "T"; dark blue	1
6281503	Codetab; roll of 500 x "W"; brown	1
6281506	Codetab; roll of 500 x "Z"; yellow	1

CODE IN ONE



Jalema has also developed a colour-coding system called Code in One. Code in

One is a total solution on a single label. Every Code in One label

has 7 cells. You determine how the cells should be coded. Any

combination of numbers, letters, logos, barcodes, addresses,

dates, etc. is possible. No matter what kind of filing and coding system

you use, Code in One is the ideal coding solution. Jalema offers three different versions, all of which are designed for

two-sided coding. This means that Code in One labels are folded around the file, making them easily visible on both

sides and ensuring a well-organised, unambiguously coded archive. And once you've received your labels, you needn't

worry about the next step, because Code in One is delivered already adhered to the document folders and ready for

use. Naturally it is also possible to order individual self-adhesive labels for sticking to your files yourself.



Easy to use. Code in One - specially produced for you - on the file, delivered ready for use. Naturally we also deliver self-adhesive labels that can be affixed to your own files.



Label Positioner

Your own colour-coding system and document folder delivered ready for use

You supply us with an ASCII or Excel file and together we determine which file or folder is most suitable for your needs. We then deliver the folders ready for use with the coding system of your choice. Jalema offers a number of different suspension files with tabs as part of the Arnato line that are highly suitable for this type of coding.

Prod. no.	Description	Size/mm.	Quantity
4310000	4 or 7-cell personalised Code in One service labels, delivered on files	195 x 30	2500

Your own colour-coding system on individual, self-adhesive labels

It is also possible to stick Code in One labels to your files yourself. Self-adhesive labels are printed on the seven cells in exact accordance with your instructions. Jalema has developed a clever device for this Code in One option called the Label Positioner, which lets you stick the labels to files quickly and easily.

Prod. no.	Description	Size/mm.	Quantity
4312500	4 or 7-cell personalised Code in One service labels, delivered on sheets	195 x 30	2500
4355200	Label Positioner		1



Code in One Sequential Series

The most basic of the Code in One labels is the self-adhesive labels with ascending series of 4 numbers (from 0000 to 0999, from 1,000 to 1,999, and so forth), each with a different colour, that are delivered on handy self-adhesive A4 sheets. If you archive contains more than 9,999 files, you can supplement the 4-number sequences with individual number labels, allowing your archive to grow up to 99,999 files!



Code in One sequential series, for an efficient, well-organised archive

Prod. no.	Description	Stand. pack.
4330000	Code in One Sequential series; 0000-0999	1
4331000	Code in One Sequential series; 1000-1999	1
4332000	Code in One Sequential series; 2000-2999	1
4333000	Code in One Sequential series; 3000-3999	1
4334000	Code in One Sequential series; 4000-4999	1
4335000	Code in One Sequential series; 5000-5999	1
4336000	Code in One Sequential series; 6000-6999	1
4337000	Code in One Sequential series; 7000-7999	1
4338000	Code in One Sequential series; 8000-8999	1
4339000	Code in One Sequential series; 9000-9999	1



CODE IN ONE ON DEMAND

Code in One on Demand is a sophisticated software programme for designing and printing your own professional colour-coding labels for use on files, videotapes, CD-ROMs, books, albums, magazines, or anything you want to file in a well-organised manner. With Code in One on Demand, you can file and retrieve products or objects easily and quickly, thus saving you considerable time (and time is money!), time that would otherwise be spent searching. The programme is excellently suited for creating colour-coding labels for work files and document-handling folders. Code in One places no limitations as far as design, format, field positions or colour combinations. The fields can be used in any order for letters, numbers, barcodes, photographs, symbols, etc. In fact, the only restrictions on the label designs are those imposed by your own creativity and your printer. The programme is exceptionally user-friendly and guides you step-by-step and in logical order through the different options. Code in One on Demand runs under Windows 98, 2000, ME, NT and XP. The package comes with a CD-ROM containing the software and a number of ready-to-use default settings, an instruction booklet, several Jockey indicator strips and a 10-step plan. Every cell that is used (with a colour, photograph, barcode, etc.) costs 1 credit. Credits can be purchased in sets of 2,500.



Colours, numbers, photographs, text, barcodes, logos... the sky's the limit!

Prod. no.	Description	Stand. pack.
4315100	Software package	1
4316500	Credits (2,500 pieces)	1
4317000	Label design	1
4321100	Labelsheets paper 1 cell, box of 100 sheets	1
4321400	Labelsheets paper 4 cells, box of 100 sheets	1
4321700	Labelsheets paper 7 cells, box of 100 sheets	1

COLOUR CODING

JOCKEY

JALEMA JOCKEY



The Jalema Jockey is a universal label holder that fits on every file and is placed in holes that you make with a perforator. Most Jalema files come pre-punched. The list of contents can be quickly and easily printed on indication strips (included). The label holders come in boxes of 50. It is also possible to use colour coding together with label holders. With this option, you print your design on the indication strips using the Code in One on Demand software programme. Individual Jockey colour labels are also available (numbers and letters), which can be easily adhered to the strip.

You can also make use of Jalema's Jockey Code in One Service. This means that we design and print the labels for you. The Jockey is also ideal for bundling 10 to 15 sheets of paper, such as a group of offers or documentation.



1. Perforate. (If you don't have files that are equipped with perforation holes)



2. Print indicator strip and adhere Jockey Label.



3. Fold the indicator strip.



4. Pull back the Jalema Jockey.



5. Insert the indicator strip into the Jockey.



6. Click the Jalema Jockey into the perforation holes with the rounded side on the inside.

Prod. no.	Description	Stand. pack.
6100509	Jalema Jockey (incl. indication strips), box of 50 label holders, blue	1
6100515	Jalema Jockey (incl. indication strips), box of 50 label holders, red	1
6100520	Jalema Jockey (incl. indication strips), box of 50 label holders, transparent	1
6205000	Jockey Labels numbers (0-9), bag of 5 sheets	1
6205200	Jockey Labels letters (A-Z), bag of 5 sheets	1
6200518	Jockey indication strips, 50 sheets of 34 strips	1
4313000	Code in One personalised, 50 sheets of 34 strips indication strips for Jockey	1

SELF-ADHESIVE LABEL HOLDERS



A self-adhesive label holder can be attached to the top or side edge of the files in which an indicator strip with room for 2 or 3 lines of text can be inserted.

Prod. no.	Description	Size/mm.	Stand. pack.
6103000	Self-adhesive label holder (5/6") with indication strips (3 lines of text), bag of 50 label holders	108 x 31	1
6202418	Indication strips for 5/6" label holder, 50 sheets of 11 strips	105 x 211	1

Jalema Filing Systems

ACCESSORIES

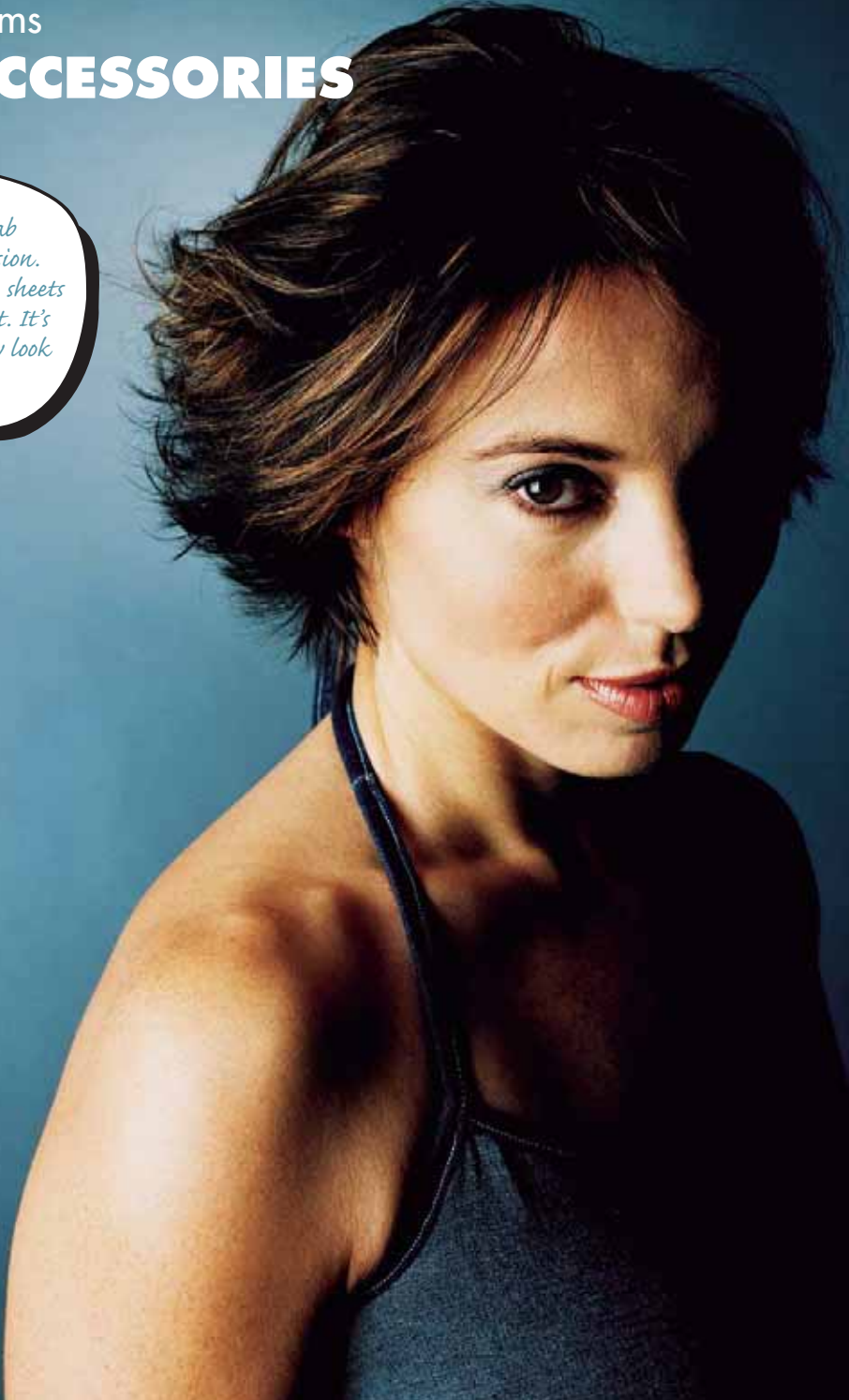

I would love to have an organised folder with tab sheets for optimum subdivision. Jalema suggested that the tab sheets be printed with my own text. It's the perfect solution and they look really well organised.

Handy tools – from the JalemaClip attachment mechanism to tab sheets – make it even easier to efficiently file and retrieve information. These well thought out accessories save you considerable time and money day in, day out.

Next to the standard tab sheets Jalema also offers a lot of customised tab sheets (own text or unusual format).

The separation and absence cards in our assortment give you overview in your archive. All these accessories save you time and money every day.

TAB SHEETS

EASY SUBDIVIDING FOR AN

The ability to subdivide information within files is both convenient and desirable. If documents are arranged by subject, subdividing makes it easier to locate individual documents within a single file. Jalema tab sheets are a simple and inexpensive way to subdivide files



effectively.



Lined white cardboard tab sheets

Jalema supplies lined tab sheets made of white cardboard. The 4 perforation holes are reinforced with Mylar plastic. The sheets are subdivided into five sections where you can adhere convenient self-adhesive tabs, which can be written on with a pen. The self-adhesive tabs come 30 to a sheet and are available in 12 different colours. The tab sheets are made of 170 gram offset cardboard.

Prod. no.	Description	Size/mm.	Stand. pack.
4902500	White tab sheets (250 sheets per package)	297 x 210 mm	1
4910002	Self-adhesive coloured tabs, blue (10 sheets of 30 tabs)	58 x 10 mm	1
4910003	Self-adhesive coloured tabs, brown (10 sheets of 30 tabs)	58 x 10 mm	1
4910005	Self-adhesive coloured tabs, light yellow (10 sheets of 30 tabs)	58 x 10 mm	1
4910006	Self-adhesive coloured tabs, yellow (10 sheets of 30 tabs)	58 x 10 mm	1
4910007	Self-adhesive coloured tabs; grey (10 sheets of 30 tabs)	58 x 10 mm	1
4910008	Self-adhesive coloured tabs, green (10 sheets of 30 tabs)	58 x 10 mm	1
4910011	Self-adhesive coloured tabs, light red (10 sheets of 30 tabs)	58 x 10 mm	1
4910013	Self-adhesive coloured tabs, orange (10 sheets of 30 tabs)	58 x 10 mm	1
4910014	Self-adhesive coloured tabs, purple (10 sheets of 30 tabs)	58 x 10 mm	1
4910015	Self-adhesive coloured tabs, red (10 sheets of 30 tabs)	58 x 10 mm	1
4910022	Self-adhesive coloured tabs, turquoise (10 sheets of 30 tabs)	58 x 10 mm	1
4910023	Self-adhesive coloured tabs, dark green (10 sheets of 30 tabs)	58 x 10 mm	1





ORDERLY FILE

Coloured Tab Sheet Sets

Jalema also supplies tab sheets with 5 or 10 coloured tabs that are reinforced with plastic, as a result of which the tabs do not easily become dirty or dog-eared. The special lined front sheet comes in grey and the coloured tab sheet in white. All tab sheets have 4 Mylar-reinforced perforation holes. The A-Z tab sheet set consists of 20 tab sheets and an index sheet. All sets are made 190 gram white offset cardboard.

Prod. no.	Description	Stand. pack.
4904500	Tab Sheet Set; 5-piece; coloured tabs	60
4905000	Tab Sheet Set; 10-piece; coloured tabs	30

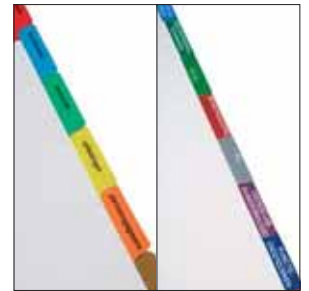

Tabs can be printed with your own texts.

Blank Tab Sheet Sets

These 5 and 10-piece blank tab sheet sets allow you to implement your own coding system. The tabs can be labelled with our Codetabs (0-9, A-Z and coloured). It's also possible to print your own text in colour on these tabs using our user-friendly Code in One on Demand software programme. When using this software, the background colour is selected automatically based on the first letter of the word. It is also possible to choose your own colours, however. The tabs have application lines for Codetabs. The sheets are made of 190 gram white offset cardboard and have 5 plastic-reinforced perforation holes.

Prod. no.	Description	Stand. pack.
4903500	Tab Sheet Set; 5-piece; blank tabs	50
4904000	Tab Sheet Set; 10-piece; blank tabs	25



Special Tabsheets sets:

Jalema also supplies a wide range of customised tab sheets at exceptionally attractive prices made of cardboard or PVC, reinforced, in a variety of colours, and more. Inquire about the possibilities we offer.

Some examples:



Various possibilities in synthetic material (polypropylene)



Black print on white cardboard with Mylar-reinforced tabs and perforation holes.



Print in your own corporate style with unusual design.

JALEMA FEELS VERY STRONGLY A

At Jalema we feel very strongly about optimum flexibility and performance. Our clever, flexible, and exceptionally user-friendly attachment mechanisms are efficient solutions for all possible storage and filing problems, big or small.



JalemaClip

The JalemaClip is a flexible attachment mechanism that has become an unparalleled success thanks to its high-quality characteristics. The JalemaClip is ideal for bundling all sizes and types of documents and has been cleverly constructed to allow documents to be inserted or removed in a matter of seconds, and without damaging the documents.

The advantages of the JalemaClip:

- Documents can be inserted and removed in a matter of seconds thanks to the clever construction of the clip.
- Will not tear perforation holes due to the flexible tube.
- Contents can be leafed through like a book.
- All documents remain readable at all times.
- Suitable for all standard perforation holes.
- Documents can be copied without being removed.
- Won't make the file bulky.
- Lead and cadmium-free.

Box of 100 clips:

Prod. no.	Cover	Flexible Brace	Clip	Stand. pack.
5710000	Yellow	Yellow	White	1
5710046	Black	Black	Black	1

FROM DOCUMENT FILE TO BOX FILE IN NO TIME

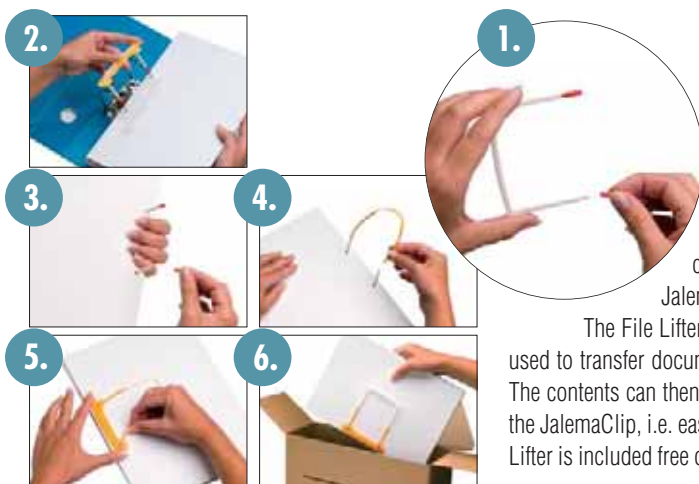

Jalema File-lifter

It's never too late to switch to the convenience of Jalema products. And we're making it even easier all the time. A good example of this is a new product we recently developed called the Jalema File Lifter. This clever device lets you quickly and easily transfer the contents of your document files to a single JalemaClip or JalemaClipex, letting you store the documents in a box file.

The File Lifter consists of two simple red slide-on connectors that are used to transfer documents from a document file mechanism to a JalemaClip. The contents can then be placed in a box file, but with the added advantage of the JalemaClip, i.e. easy copying, insertion and removal of documents. The File Lifter is included free of charge with every box of JalemaClip and JalemaClipex.

BOUT FLEXIBILITY AND PERFORMANCE

JalemaClipex For Permanent Storage

The JalemaClipex combines the functional properties of the standard JalemaClip with an attachment mechanism for the permanent storage of files. The JalemaClipex is a flexible device that is free of plasticizers, PVC and acids. Plasticizers can corrode documents that are stored for longer periods of times. Thanks to a special composition of a new material, harmful softening agents can be omitted from the flexible brace. The JalemaClipex complies with all requirements for permanent storage as laid down in the Public Records Act. Moreover, the flexible JalemaClipex device does not cause any mechanical damage to valuable documents. The JalemaClipex has been given a unique colour - petrol-white - for easy recognition.



The JalemaClipex complies fully with the strict ICN quality requirements 12, as laid down by the Dutch Public Records Act, which all government bodies must adhere to. This means that this mechanism guarantee long-term storage and do not affect the documents being stored.



Prod. no.
5720049

Description
JalemaClipex: box of 100

Stand. pack.
1



How to use the JalemaClip/JalemaClipex:



- Using your thumb and forefinger, press down on the ends of the plastic cover and slide the flexible brace out of the tab pieces.



- Determine the location in the file where you need to be, and then push the pages in front of it completely to the left on top of the clip.



- To insert a document, remove the flexible brace from the clip and insert the new document (by way of the clip).



- To remove a document, follow the above instructions, except use the flexible brace to remove the document (to prevent tearing).



- To insert documents it is best to make use of the clip on the left side.

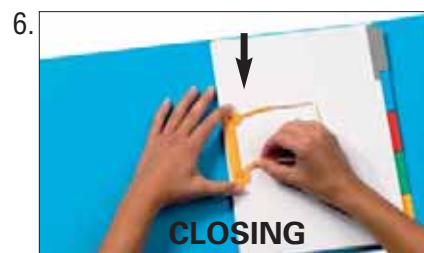

- Close the device again by following the above instructions in reverse order, making sure to firmly tighten and clamp the flexible brace between the tab pieces on the cover.

ACCESSORIES



JalemaClip-Plus

Yellow-white JalemaClip with insert strip. The insert strip makes it possible to place the JalemaClip attachment mechanism in any ring binder or document file, an excellent solution for storing separate files in a single binder. The insert strip is made of environmentally friendly polypropylene. Available in an assorted package of red, blue, grey and black insert strips.

Prod. no. 5712525
Description JalemaClip-Plus: box of 100

Stand. pack.
6

JalemaClip-Stickup

The JalemaClip-Stickup is a self-adhesive strip with the same characteristics and advantages as the standard JalemaClip. The added advantage of the Stickup is that you can determine exactly where it should be placed in the file. The JalemaClip-Stickup makes an efficient fastener file out of any binder, folding file or offer folder.

Prod. no. 5715500
Description JalemaClip-Stickup: box of 100

Stand. pack.
6



With the JalemaClip-Stickup you turn each folding or quotation file into a functional fastener file.

Stripper-Stickup

The Stripper is also characterised by simplicity and user-friendliness. The Stripper is a self-adhesive attachment mechanism consisting of a self-adhesive white strip (with no sharp edges because it is PE coated) and a plastic cover. Because the Stripper is self-adhesive, it can be placed anywhere in the file or folder. The Stripper adheres firmly to paper, cardboard, plastic, and even metal. Capacity: 20 mm.

Prod. no. 7170007
Description Stripper-Stickup (15 x 2 cm): box of 100

Stand. pack.
15



SELF-ADHESIVE POCKETS

The clear self-adhesive A4 pocket can be attached to the files for displaying samples, proofs, artwork or job-tickets. For CDs and diskettes also a special self-adhesive pocket is available.

Prod.nr.	Description	Stand. Pack.
6101800	A4 pocket; self-adhesive	50
6102600	CD or Zip-disk pocket with flap; self-adhesive	50



CARDS

Absence card

Sometimes files are intended for frequent consultation. In order to clearly indicate that a file is missing from the archive, Jalema supplies 'file unavailable' cards. These cards have a single suspension point and the same format as a file, and are made of red Colorkraft cardboard. These cards are placed where the file would normally hang. There is a tab that projects above the top of the files as an extra attention-getter. The absence cards are pre-printed with lines for writing information on who removed the file concerned and when.

Prod.no.	Description	Size/mm.	Stand.pack.
5901600	Absence card	350 x 250	25

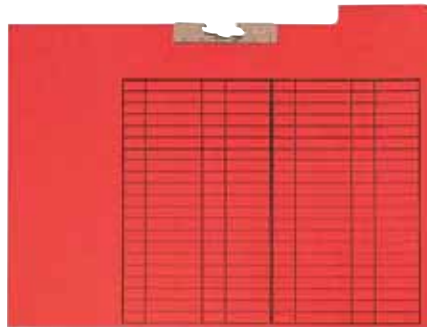

Separation cards with label holder

Jalema's separation cards are made of double-sided, grey lacquered 1.2 mm thick suitcase board. These sturdy, stable cards enable you to easily subdivide your archive. The cards have a self-adhesive label holder with a strip and have three rounded corners. The separation cards project 20 mm from the files on the front. Instead of using the window, you can also adhere alphabetical, numerical or other Codetabs to the card. There are separation cards available for A4 (320 mm files) and folio (350 mm files).

Prod.no.	Description	Size/mm.	Stand.pack.
5955007	Separation card for A4 files	340 x 130	25
5955200	Separation card for folio files	370 x 130	25
5955400	X-ray Separation card, grey	480 x 130	25



FILE BOX

FILE BOX



Made of heavy, double-lined kraft cardboard (850 gr.), the Jalema Municipal Archives File Box is exceptionally strong. The score marks in the box file are virtually guaranteed to never break, even after frequent use. And the documents stored in the Municipal Archives File Box will remain absolutely dust-free. Even the thumb hole is sealed against dust. The box files are easy to put together using metal connecting pieces. The open punched grooves render it unnecessary to remove cardboard. The Box File has a capacity of 11,5 cm. The box files have a blind-stamped square for the index and come with a label. The pH value of the cardboard is neutral, thus optimally protecting your old archive against the harmful effects of acids.

Prod. no.	Description	Stand. pack.
2303700	Folio Municipal File Box with connecting pieces and labels (37 x 26 x 11,5 cm)	50
7900500	Connecting pieces: bag of 200	1
2976000	Labels: bag of 50	1

To ensure that the documents stored in the box file remain accessible at all times, Jalema supplies clever fastening mechanisms called the JalemaClip and JalemaClipex. For more information on these ingenious devices, see page 42 and 43.

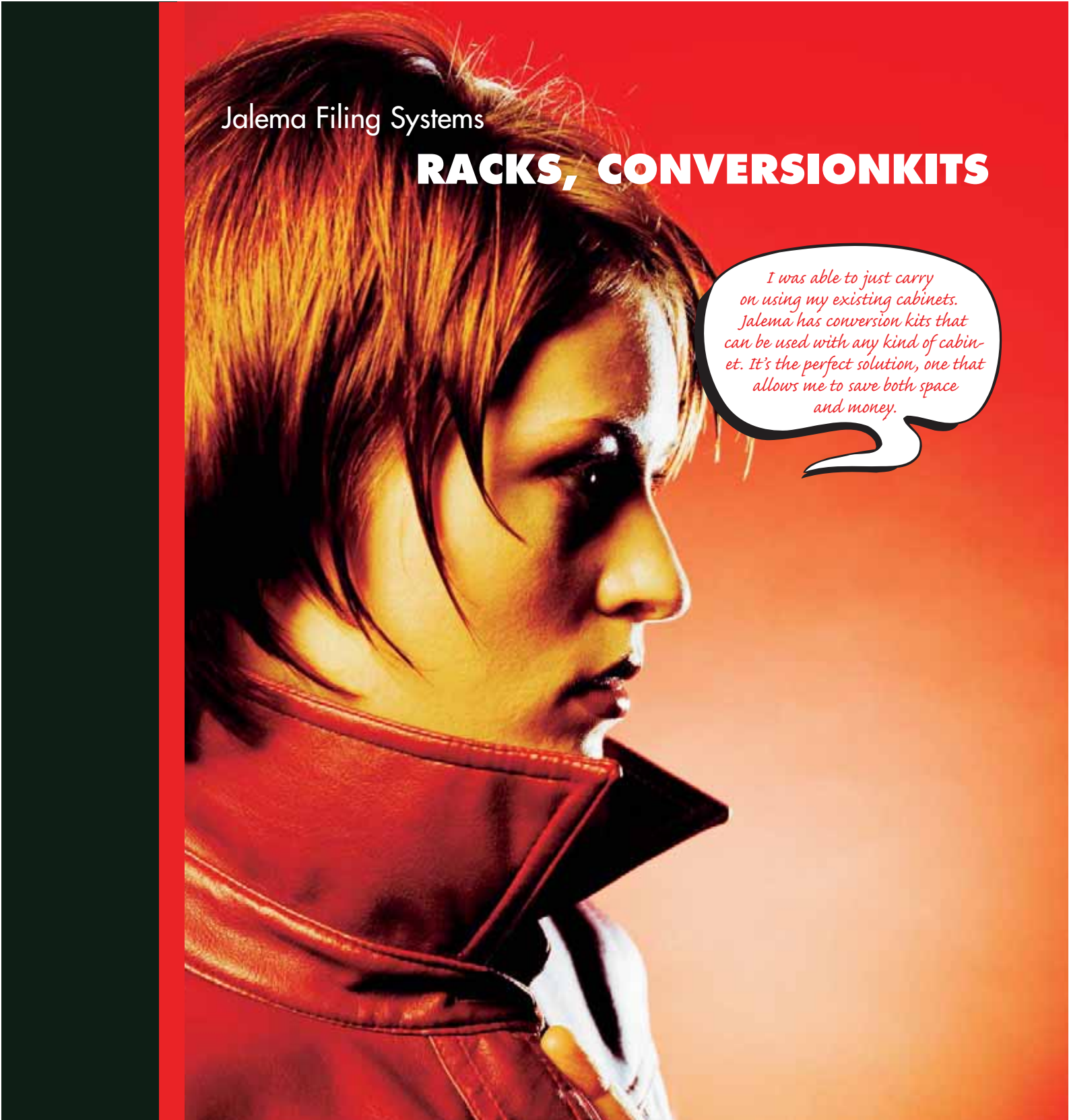

Jalema Filing Systems

RACKS, CONVERSIONKITS

I was able to just carry on using my existing cabinets. Jalema has conversion kits that can be used with any kind of cabinet. It's the perfect solution, one that allows me to save both space and money.

Jalema racks allow you to create a well-organised, easily accessible and space-saving archive, whatever the nature and size of your filing system. Whether you are looking for a solution for a working archive in your office or a static archive in the basement, Jalema offers various space-saving racks. If you would rather use your existing furniture, Jalema also offers conversion kits that let you take advantage of the effective Jalema filing system in combination with your own wooden or metal cabinets.

PROFILE OF A VERSATILE FILING



Jalema has been the filing partner of choice for decades as a result of its high-quality range of clever racks and accessories, all of which are practical solutions based on sophisticated techniques. Jalema filing systems combine efficiency with a saving of space and time, safety and flexibility, automatically resulting in a pleasant working environment.

Jalema's lateral filing systems in which files are suspended vertically creates a more harmonious office climate. An added advantage is that the impressive capacity of the filing racks leads to more elbowroom and a more efficient workspace.

Jalema supplies two different kinds of profiles: the Jalema profile, which is suitable for an archive with a maximum width of 1200 mm and for A4 and folio files, and the heavier Duo profile for larger files. All Jalema racks come complete with the Jalema profile, with or without files and/or your own coding system, or with Jalema's unique colour coding systems, available at extra cost. Jalema profiles are extremely versatile and can be built into nearly any existing (wooden or metal) cabinet or rack.

CONVERSION KITS



The conversion kits are designed for use with just about any existing cabinet or rack. There are kits available for wooden as well as metal furniture. Depending on the size of the files, either the Jalema profile or the Duo profile is used. The Jalema profile is designed for use with files up to the folio format and up to 1200 mm in length. The sturdier Duo profile is used for larger files. The interior depth of the cabinet does not have to be greater than the width of the file.

SYSTEM

JALEMA PROFILE

The conversion kits can be fitted into virtually any cabinet or rack. The assembly itself is as easy as putting in a shelf.

The profile support replaces the shelf support and the profile is supplied in any desired length. The conversion kits let you put together an efficient Jalema filing system quickly and at little cost. Profile supports (5803300) are used for cabinets with perforation distances of up to 330 mm. Profile support 5805000 is needed for cabinets with depths of 330 to 500 mm.

Prod. no.	Description	Stand. pack.
5801900	Profile holder for wooden cupboards: set of 2 pcs.	1
5803300	Profile Carrier (230-330 mm); set of 2 pieces	1
5805000	Profile Carrier (330-500 mm); set of 2 pieces	1
5814000	Jalema Profile; length 800 mm	1
5814500	Jalema Profile; length 900 mm	1
5814800	Jalema Profile; length 965 mm	1
5815000	Jalema Profile; length 1000 mm	1
5815500	Jalema Profile; length 1050 mm	1
5815600	Jalema Profile; length 1065 mm	1
5816800	Jalema Profile; length 1190 mm	1
5817100	Jalema Profile; special length: up to 995 mm	1
5817200	Jalema Profile; special length: 1010 up to 1195 mm	1
5817300	Jalema Profile; special length: 1200 up to 5000 mm	1
5821700	Duo Profile; length: 500 up to 1000 mm	1
5821900	Duo Profile; length: 1001 up to 1195 mm	1



Jalema Profile



Jalema and Duo Profiles can be easily installed in wooden furniture.



Easy to install in virtually any metal cabinet.



Jalema Profile



Duo Profile

Index of allowed load Jalema profile in kg

Length	Profile carriers in front and rear cupboard walls / Racks	Profile carriers in side walls / Holders	Uni rack	H-rack / Wall filing rack	Jalema Mobile System
600	133	143	-	-	-
700	108	118	-	-	-
800	88	98	-	128	125
900	72	82	-	107	104
1.000	60	70	80	90	87
1.100	52	60	-	81	72
1.200	47	54	-	73	64

RACKS



Uni Rack

Jalema Uni Racks are suitable for use with Art and Grafi-Files, as well as other types of files. Uni Racks are supplied as do-it-yourself kits, including clear assembly instructions. The assembly is quite simple and the racks can be expanded on both sides in an unlimited quantity. The profiles (available separately) are height adjustable in increments of 3 cm. Smaller-sized files are suspended in the upper section and larger files in the lower section. The maximum evenly distributed load is 200 kg per profile. Jalema offers two types of Uni Racks: one that is 400 mm deep and suitable for files up to 390 x 495 mm and a 550 mm deep rack suitable for files up to 640 x 795 mm. A special rack that can be equipped with 6 rows is available for A4 files.

Prod. no.	Description	Stand. pack.
6440000	Basic Unit, 400 mm deep	1
6440500	Extension Unit, 400 mm deep	1
6455000	Basic Unit, 550 mm deep	1
6455500	Extension Unit, 550 mm deep	1



A4/A3 Uni Rack

A special Uni Rack is available for A4/A3 files. This self-assembly rack has 6 Jalema profiles of 946 mm in length. Jalema profiles must be ordered separately. Assembly of the Uni Racks is extremely simple and the rack can be extended with unlimited numbers of extension units. The dimensions of this rack are: 2280 mm high, 400 mm deep and 1000 mm wide. The extension unit is 970 mm wide. The maximum evenly distributed load for each Jalema profile is 60 kg. The Uni Rack comes in the colour grey (RAL 7015).

Prod. no.	Description	Stand. pack.
6494000	Uni Rack, Basic Unit, 400 mm deep; for 6 rows of A4 files	1
6494500	Uni Rack, Extension Unit, 400 mm deep; for 6 rows of A4 files	1
6496000	Set of 6 Jalema profiles for the Uni Rack	1



Continuous Filing Rack

Continuous Filing Racks are racks without any obstructive sidewalls, making it possible to slide files across the entire width of the rack, ideal for large archives. Available as a single (H1) or double (H2) rack. All widths from 600 mm are available in units of 100 mm. (Not possible are the widths 900 and 1100 mm). The continuous filing racks have 6 (2015 mm high) or 7 (2345 mm high) Jalema profiles.

A support should be placed at least every 1000 mm. The H1 and H2 racks are supplied as do-it-yourself kits. Naturally Jalema can assemble them for you. The racks come in the colour grey (RAL 7015).

Prod. no.	Description	Stand. pack.
6910633	H1 Rack with 6 Jalema Profiles	1
6920633	H2 Rack with 2 x 6 Jalema Profiles	1
6910733	H1 Rack with 7 Jalema Profiles	1
6920733	H2 Rack with 2 x 7 Jalema Profiles	1



Info Shelf

The Info Shelf is a handy shelf that can be attached to the frame of continuous filing racks and which can be used to temporarily place files when searching through them or inserting or removing documents. After you are done with the shelf, simply fold it up and out of the way so that it does not obstruct the aisle. The Info Shelf is wide enough to easily leaf through an open file or place two piles of files next to each other. The Info Shelf is made of 100% scratch-resistant volkern sheet and comes in the colour grey.

Prod. no.	Description	Max. evenly distributed load/kg	Size/mm.
6421000	Info Shelf	20	695 x 335

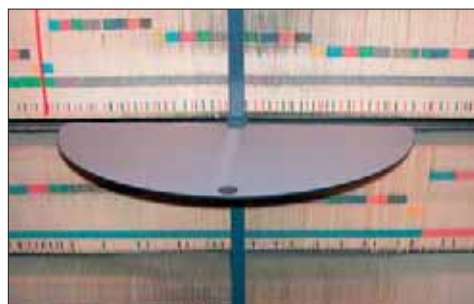



Wall-Mounted Filing Rack

The Wall-Mounted Filing Rack is ideal for use as a small archive close to the workspace, thereby placing important files within easy reach. The racks are available in two lengths: 800 and 1600 mm. Assembly materials included.

Prod. no.	Description	Max. evenly distributed load/kg	Size/mm.
5810800	Wall-Mounted Filing Rack	100	800 x 360 x 200
5811600	Wall-Mounted Filing Rack	2 x 75	1600 x 360 x 200



Wall Unit

The Wall Unit is particularly handy for use next to the workspace. Because it is small in size, it does not take up much space and can be mounted on virtually any wall. The profile length is 200 mm and all assembly materials are included.

Prod. no.	Description	Max. evenly distributed load/kg
5812500	Wall Unit	25



Table Arm

The Table Arm is a functional aid for your desk or worktable. The Table Arm is fastened with a solid clamp to any desk or tabletop having a thickness of 10 to 80 mm. The useable capacity of the Table Arm is 140 mm with a height of 520 mm

Prod. no.	Description	Max. evenly distributed load/kg
6431200	Table Arm	20

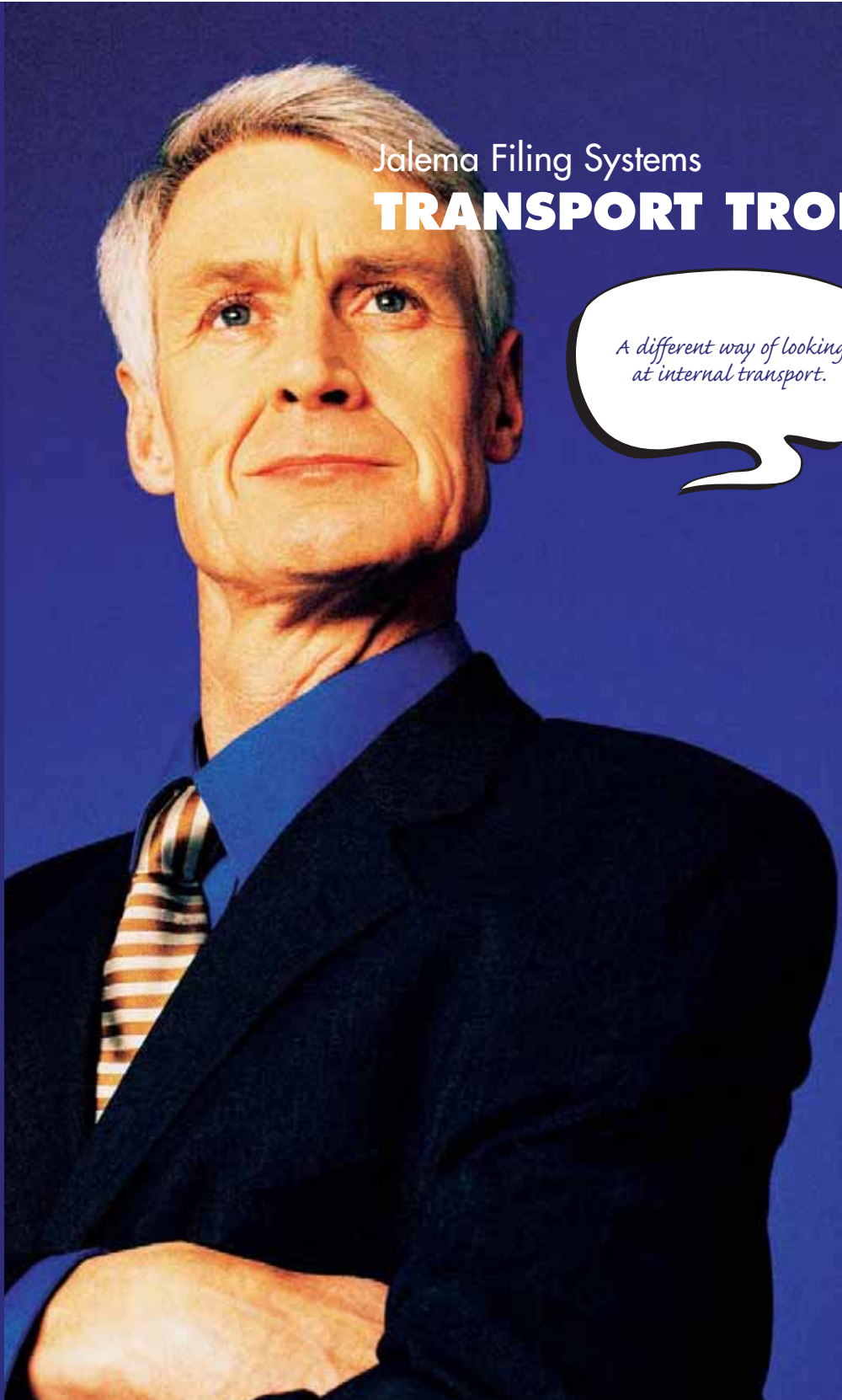
A photograph of a middle-aged man with grey hair, wearing a dark blue suit jacket, a blue shirt, and a striped tie. He has his arms crossed and is looking slightly upwards and to the right. The background is a solid blue color.

Jalema Filing Systems

TRANSPORT TROLLEYS

*A different way of looking
at internal transport.*

Jalema transport trolleys stand out thanks to their practicality, exceptional ease of use and contemporary styling. The trolleys are available in two widths and are custom equipped to meet your requirements. Options to choose from include profiles for suspension files and CD files, shelves, roll-down shutter cabinets and drawer cabinets, or combinations of all of these, resulting in a fully customised trolley.

TRANSPORT TROLLEYS



Jalema transport trolleys stand out thanks to their practicality, exceptional ease of use and contemporary styling. The trolleys are available in two widths and height, each using a universal hole pattern, thereby allowing for maximum versatility. Available options are profiles for suspension files and CD storage, shelves, roll-down shutter cabinets and drawer cabinets, or combinations of all of the above, resulting in a fully customised trolley.



The advantages of Jalema trolleys:

- Flexible and multifunctional
- The possibility to adapt the configuration to your needs:
 - Profiles (for suspension files and CD storage).
 - Shelves (for a variety of purposes, from cassettes containing upright files to drawer cabinets for medicine).
 - Quando cabinet with roll-down shutter and lock (available on wide trolleys only).
- Contemporary design: blends in well with today's working environments.
- Highly accessible.
- Extremely stabile construction.
- Available in two colour combinations: platinum grey/anthracite and sapphire blue/anthracite.

A New Look at Internal Transport

The transport trolleys have an extremely low rolling resistance because they are fitted with large wheels, two of which are equipped with multi-directional brakes (in the rolling and rotation directions). An ergonomically designed handle that supports the natural positioning of the hands makes the trolleys easy to manoeuvre and excellently suited for busy working environments. The transport trolleys are accessible on two sides and equipped with both a base plate and top plate for additional filing capacity.

There are two basic versions available: a wide version and a narrow version. The wide model offers a considerable filing capacity, whereas the narrow model is highly manoeuvrable and therefore ideal for frequent internal transport.

TRANSPORT TROLLEYS

Well thought out designs:

- Large wheels with extremely low rolling resistance, as a result of which cords, low thresholds, and elevators are no longer obstacles.
- Easy manoeuvrability thanks to ergonomically designed handle.
- Available in wide and narrow versions, offering a choice between optimum capacity and optimum manoeuvrability.
- Equipped with guards on all wheels to protect walls, doorposts and the trolley itself.
- Available in two colour combinations: platinum grey/anthracite and sapphire blue/anthracite.



Cords, thresholds and other minor obstacles are no longer problematic thanks to large wheels with extremely low rolling resistance.

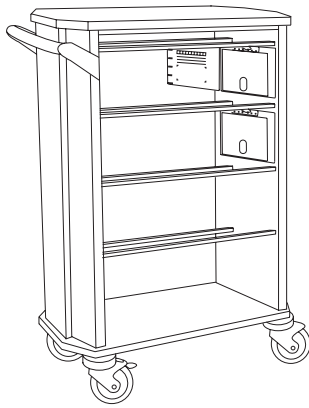

DIMENSIONS

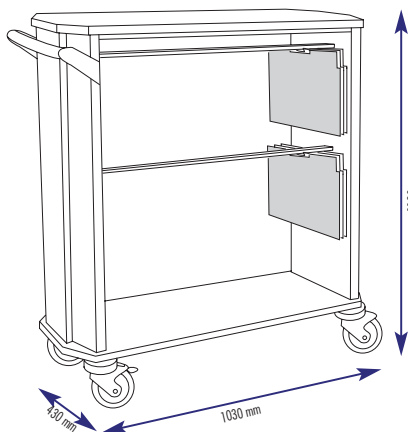
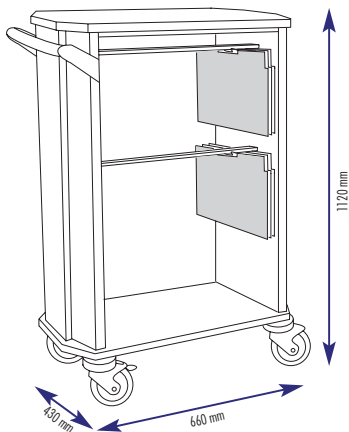

COMPLETE COMBINATIONS OF TRANSPORT TROLLEYS

The transport trolleys come in two basic versions:

- Wide transport trolley with handle
- Narrow transport trolley with handle

These models form the basis of a wide range of possible configurations, customised solutions that are tailored to your needs and desires.

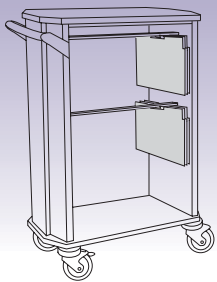

64002**
Narrow, 2 profiles
A4/folio suspension files

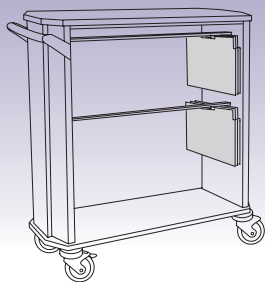

64003**
Wide, 2 profiles
A4/folio suspension files

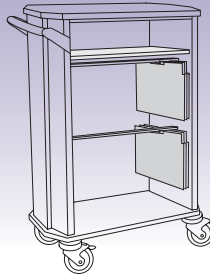

64006**
Narrow, 2 profiles, 1 shelf
A4/folio suspension files

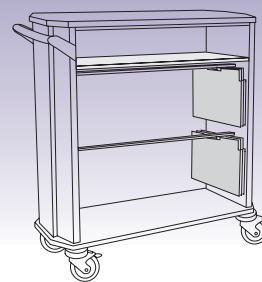

64007**
Wide, 2 profiles, 1 shelf
A4/folio suspension files



64010**
Narrow, 2x4 profiles
8 rows of CD files



64011**
Wide, 2x4 profiles
8 rows of CD files

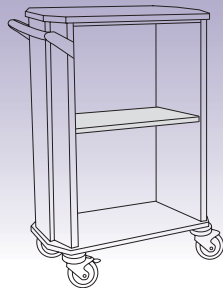

64018**
Narrow, 1 shelf

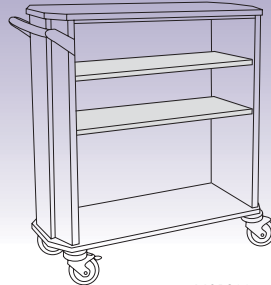

64019**
Wide, 2 shelves

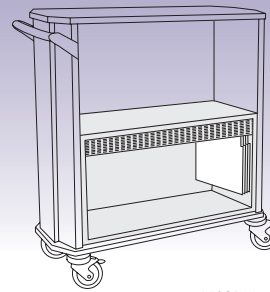

64021**
Wide, 1 Quando
A4/folio suspension files



64022**
Wide, 1 Quando, 1 shelf
A4/folio suspension files

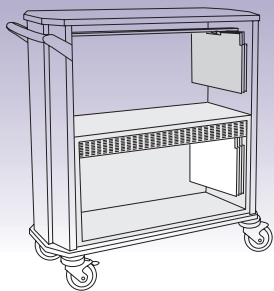

64023**
Wide, 1 Quando, 1 profile
A4/folio suspension files

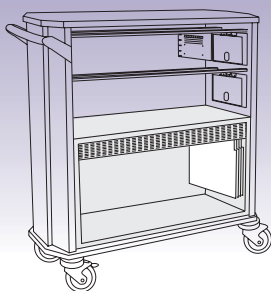

64024**
Wide, 1 Quando, 2x2 profiles
A4/folio suspension files

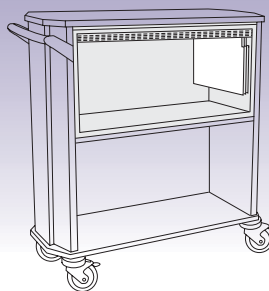

64022**
Wide, 1 Quando, 1 shelf
A4/folio suspension files

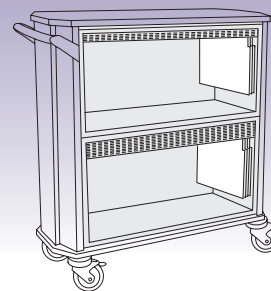

64025**
Wide, 2 Quandos
A4/folio suspension files

Jalema Filing Systems

VARIOUS PRODUCTS

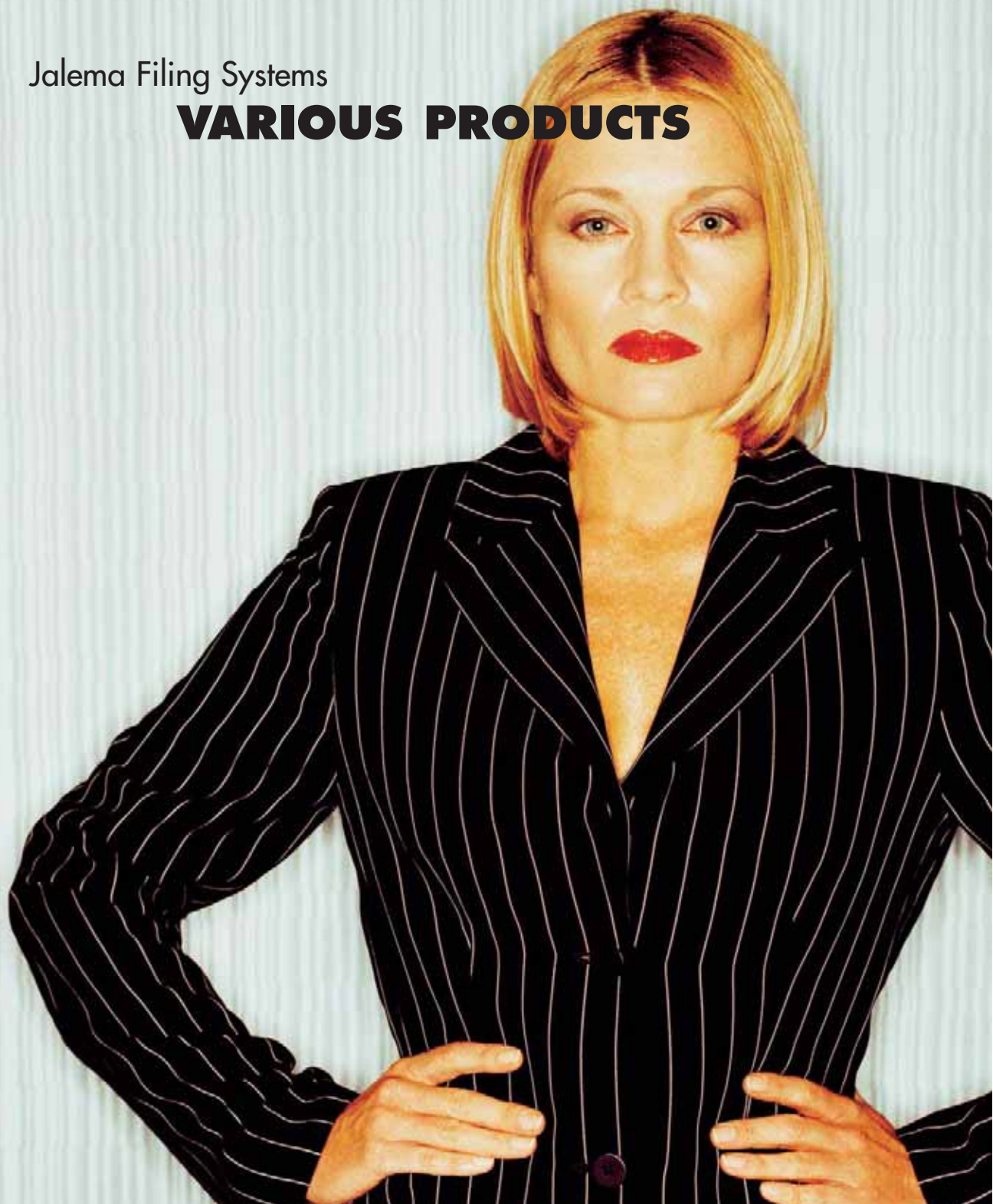

Products:

- JIM Lite
- Grafi-System

JIM

JIM Lite

JIM Lite is a simple software package for filing and managing physical files. The software can be adjusted flexibly, making it ideal for organisations and tailored to your specific needs. JIM Lite significantly reduces the time spent searching, thereby saving you time and, ultimately, money.

Every file is given a unique file number in JIM Lite. You assign each individual file specific characteristics, such as the client number, name, address, date of birth, and so forth. You determine which characteristics are important for filing, each of which can be used later on to locate specific files.



File management is limited to locating, entering, changing and removing files. Each of these actions can be carried out quickly and easily. To speed up the entry process, a reference file (such as a list of debtors) can be used. This reference file can be imported using the management functions.



In addition to these basic functions, you can also register which files have been lent out and returned, thereby enabling you to keep track of the logistics process and stay up-to-date on the location of your files at all times.

JIM Lite can be downloaded for free at
www.jalema.com.

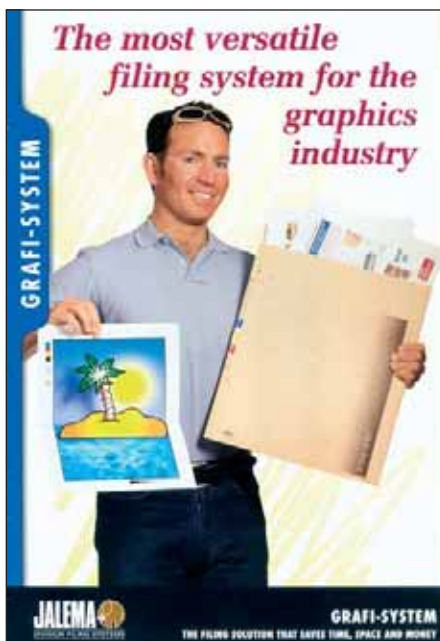

GRAFI-SYSTEM:

The Versatile Filing System for the Graphics Industry

Grafi-System from Jalema is an integrated filing system specially geared to the demands and desires of the graphics industry. It is the perfect filing solution for the entire graphics process, from pre-press to printing. The basis of this versatile system is solidly constructed multifunctional files that are available in a wide range of sizes and designs. Jalema also offers ideal solutions for filing digital storage media. The line also includes racks, accessories and colour coding options. Request a brochure by writing to: info@jalema.com